

IBM

@server™

iSeries

OptiConnect for OS/400

*Version 5*

SC41-5414-02







iSeries

OptiConnect for OS/400

*Version 5*

SC41-5414-02

**Note**

Before using this information and the product it supports, be sure to read the information in "Notices" on page 71.

**Third Edition (May 2001)**

This edition applies to version 5, release 1, modification 0 of the IBM Operating System/400<sup>®</sup> licensed program (product number 5722-SS1) and to all subsequent releases and modifications until otherwise indicated in new editions.

This edition replaces SC41-5414-01. This edition applies only to reduced instruction set computer (RISC) systems.

© **Copyright International Business Machines Corporation 1997, 2001. All rights reserved.**

US Government Users Restricted Rights – Use, duplication or disclosure restricted by GSA ADP Schedule Contract with IBM Corp.

# Contents

**Figures . . . . . v**

**Tables . . . . . vii**

**About OptiConnect for OS/400®  
(SC41-5414) . . . . . ix**

Who should read this book . . . . . ix

Operations Navigator . . . . . ix

Installing Operations Navigator . . . . . ix

Prerequisites and related information . . . . . x

How to send your comments . . . . . x

**Summary of changes . . . . . xi**

**Chapter 1. OptiConnect Overview. . . . 1**

What is OptiConnect? . . . . . 1

How does OptiConnect Work? . . . . . 3

    HSL OptiConnect . . . . . 3

    Virtual OptiConnect . . . . . 4

    SPD OptiConnect . . . . . 5

    Mixed Technology Environments . . . . . 7

OptiConnect/400 Capabilities . . . . . 8

**Chapter 2. OptiConnect Requirements 11**

Software Requirements . . . . . 11

Installing OptiConnect . . . . . 11

Hardware Requirements . . . . . 12

SPD OptiConnect Configurations . . . . . 12

Verifying Installation . . . . . 15

**Chapter 3. Understanding the  
OptiConnect Environment . . . . . 17**

SPD OptiConnect Terminology . . . . . 17

HSL OptiConnect Terminology . . . . . 18

Application Structure . . . . . 18

OptiConnect Components . . . . . 19

QSOC Subsystem . . . . . 20

OptiConnect Job Descriptions . . . . . 22

**Chapter 4. Managing the OptiConnect  
Network . . . . . 23**

Starting OptiConnect . . . . . 23

Ending OptiConnect . . . . . 23

Tips on Starting and Stopping your System with  
OptiConnect . . . . . 23

Getting Information about OptiConnect Activity . . 24

    Work with Active Jobs (WRKACTJOB) . . . . . 24

    Work with OptiConnect Activity (WRKOPCACT) 25

Display OptiConnect Link Status (DSPOPCLNK) 31

Determining Hardware Resources . . . . . 35

**Chapter 5. Setting up and Customizing  
OptiConnect . . . . . 37**

Utilizing OptiConnect . . . . . 37

Setting up Fastpath OptiConnect Routing . . . . . 37

Setting up Extended Function Path Routing . . . . 39

Customizing OptiConnect . . . . . 44

    Routing SNADS over OptiConnect . . . . . 44

    Initial Library List . . . . . 45

    Changing QUSER Access Authority . . . . . 45

    QYYCDTSU Job Description . . . . . 46

    QYYCMGR Job Description . . . . . 47

    OptiConnect Performance Factors . . . . . 49

Advanced OptiConnect Customization . . . . . 50

    SQL over OptiConnect . . . . . 50

    Remote Journal Function . . . . . 51

    Use of Mode Tables . . . . . 52

    Security Considerations using the OptiConnect  
    Mode Table . . . . . 54

    OptiConnect Mode Table Reload . . . . . 56

    Journaling OptiConnect Transactions . . . . . 57

    Remote Job Submission . . . . . 57

**Chapter 6. TCP/IP over OptiConnect . . 61**

Features . . . . . 61

    Defining the OptiConnect Interface . . . . . 61

**Chapter 7. OptiConnect Problem  
Determination. . . . . 65**

Reestablishing System Connections when  
OptiConnect is Installed . . . . . 66

**Appendix A. Messages . . . . . 67**

**Appendix B. OptiConnect Cluster  
Diagnostics. . . . . 69**

**Notices . . . . . 71**

Programming Interface Information . . . . . 73

Trademarks . . . . . 73

**Bibliography . . . . . 75**

iSeries 400 . . . . . 75

**Index . . . . . 77**



---

## Figures

1. HSL OptiConnect . . . . .	4	23. Displaying Resource Details . . . . .	36
2. Virtual (inter-partition) OptiConnect . . . . .	5	24. Creating a DDM file to use OptiConnect (View 1). . . . .	38
3. SPD OptiConnect . . . . .	6	25. Creating a DDM file to use OptiConnect (View 2). . . . .	39
4. OptiConnect interoperability . . . . .	8	26. Create Controller Description on SYSTEMA to connect to SYSTEMB . . . . .	40
5. Single-Hub SPD OptiConnect Cluster . . . . .	13	27. Create Device Description on SYSTEMA to attach to controller description SYSBCTL. . . . .	41
6. Dual-Hub SPD OptiConnect Cluster . . . . .	14	28. Create Controller Description on SYSTEMB to connect to SYSTEMA . . . . .	41
7. CPU Utilization by OptiConnect for OS/400 . . . . .	18	29. Create Device Description on SYSTEMB to attach to controller description SYSACTL . . . . .	42
8. Display Autostart Job Entries . . . . .	21	30. Vary Configuration on SYSTEMA to vary on controller SYSBCTL . . . . .	43
9. Display Job Queue Entries . . . . .	21	31. Vary Configuration on SYSTEMB to vary on controller SYSACTL. . . . .	43
10. Display Routing Entry Detail. . . . .	22	32. Display Job Description - QYYCDTSU Job . . . . .	46
11. Work with Active Jobs . . . . .	25	33. Display Job Description - QYYCMGR. . . . .	47
12. Work with OptiConnect Activity Display . . . . .	26	34. Add RDB Directory Entry. . . . .	51
13. Work with OptiConnect Jobs Display . . . . .	28	35. Work with data in a file . . . . .	52
14. Work with OptiConnect Jobs and Tasks (View 1). . . . .	29	36. Remote Job Submission Source System . . . . .	59
15. Work with OptiConnect Jobs and Tasks (View 2). . . . .	30	37. Remote Job Submission Target System . . . . .	60
16. Display OptiConnect Link Status, Part 1 . . . . .	31		
17. Display Loop Details . . . . .	32		
18. Display Connection Details . . . . .	32		
19. Display OptiConnect Link Status . . . . .	33		
20. Display OptiConnect Link Status . . . . .	33		
21. Display OptiConnect Link Status . . . . .	34		
22. Work with Coupled Resources . . . . .	35		



---

## Tables

1.	HSL Loop port availability for HSL OptiConnect . . . . .	3
2.	Hardware Required for SPD OptiConnect System . . . . .	12
3.	Hardware Required for HSL OptiConnect System . . . . .	12
4.	Fields in the Mode table . . . . .	53



---

## About OptiConnect for OS/400® (SC41-5414)

This information provides an overview of the OptiConnect for OS/400 licensed program. OptiConnect allows you to connect multiple iSeries 400 servers using dedicated system buses. This book provides information on the following topics:

- Understanding OptiConnect components
- Installing OptiConnect
- Operating OptiConnect
- Identifying OptiConnect messages

---

### Who should read this book

This book is for those people who are responsible for installing, using, and maintaining OptiConnect on their iSeries 400®. You should be familiar with iSeries 400 Version 5 Release 1, as some functions may not be available in earlier releases.

---

### Operations Navigator

IBM iSeries Operations Navigator is a powerful graphical interface for managing your iSeries and AS/400e servers. Operations Navigator functionality includes system navigation, configuration, planning capabilities, and online help to guide you through your tasks. Operations Navigator makes operation and administration of the server easier and more productive and is the only user interface to the new, advanced features of the OS/400 operating system. It also includes Management Central for managing multiple servers from a central server.

For more information on Operations Navigator, see the iSeries Information Center.

---

### Installing Operations Navigator

To use Operations Navigator, you must have Client Access installed on your Windows® PC. For help in connecting your Windows PC to your iSeries 400 server, consult *Client Access Express for Windows - Setup*, SC41-5507-02.

Operations Navigator is a separately installable component of Client Access that contains many subcomponents. If you are installing for the first time and you use the **Typical** installation option, the following options are installed by default:

- Operations Navigator base support
- Basic operations (messages, printer output, and printers)

To select the subcomponents that you want to install, select the **Custom** installation option. (After Operations Navigator has been installed, you can add subcomponents by using Client Access Selective Setup.)

After you install Client Access, double-click the **Operations Navigator** icon on your desktop to access Operations Navigator and create a connection.

---

## Prerequisites and related information

Use the iSeries Information Center as your starting point for looking up iSeries and AS/400e technical information. You can access the Information Center two ways:

- From the following Web site:  
`http://www.ibm.com/eserver/iseries/infocenter`
- From CD-ROMs that ship with your Operating System/400 order:  
*iSeries Information Center*, SK3T-4091-00. This package also includes the PDF versions of iSeries manuals, *iSeries Information Center: Supplemental Manuals*, SK3T-4092-00, which replaces the Softcopy Library CD-ROM.

The iSeries Information Center contains advisors and important topics such as CL commands, system application programming interfaces (APIs), logical partitions, clustering, Java, TCP/IP, Web serving, and secured networks. It also includes links to related IBM Redbooks and Internet links to other IBM Web sites such as the Technical Studio and the IBM home page.

With every new hardware order, you receive the following CD-ROM information:

- *iSeries 400 Installation and Service Library*, SK3T-4096-00. This CD-ROM contains PDF manuals needed for installation and system maintenance of an IBM @server iSeries 400 server.
- *iSeries 400 Setup and Operations CD-ROM*, SK3T-4098-00. This CD-ROM contains IBM iSeries Client Access Express for Windows and the EZ-Setup wizard. Client Access Express offers a powerful set of client and server capabilities for connecting PCs to iSeries servers. The EZ-Setup wizard automates many of the iSeries setup tasks.

For related information, see the “Bibliography” on page 75.

---

## How to send your comments

Your feedback is important in helping to provide the most accurate and high-quality information. If you have any comments about this book or any other iSeries documentation, fill out the readers’ comment form at the back of this book.

- If you prefer to send comments by mail, use the readers’ comment form with the address that is printed on the back. If you are mailing a readers’ comment form from a country other than the United States, you can give the form to the local IBM branch office or IBM representative for postage-paid mailing.
- If you prefer to send comments by FAX, use either of the following numbers:
  - United States, Canada, and Puerto Rico: 1-800-937-3430
  - Other countries: 1-507-253-5192
- If you prefer to send comments electronically, use one of these e-mail addresses:
  - Comments on books:  
`RCHCLERK@us.ibm.com`
  - Comments on the iSeries Information Center:  
`RCHINFOC@us.ibm.com`

Be sure to include the following:

- The name of the book or iSeries Information Center topic.
- The publication number of a book.
- The page number or topic of a book to which your comment applies.

---

## Summary of changes

### What are the new changes?

OptiConnect for OS/400 now supports HSL OptiConnect, which is the system to system connection that uses the High Speed Link (HSL) technology. The V4R5 iSeries 400 model 830 and 840 HSL port hardware can be upgraded to support HSL OptiConnect, which is base for all models starting in V5R1. There are no additional hardware requirements.



---

## Chapter 1. OptiConnect Overview

The planning and managing of a computing system involves many decisions, such as where to place files, where to attach communications lines, and where to locate the most critical applications. Each of the systems involved limit these decisions. These limits include:

- Processing capacity limits
- Distribution of users and applications across systems
- Maximum amount of storage, or maximum number of communications lines that are attached to the server

OptiConnect for OS/400 provides solutions to many of these problems by enabling capacity growth through shared database clustering. The OptiConnect cluster not only will achieve **horizontal growth** and **high availability**, but will aid in data warehousing and database parallelism architectures.

**Horizontal growth:** By separating database operations from application workload, multiple systems can operate as a cluster to grow computing power beyond what a single server can provide. It is important to understand that not all applications are favorable to this type of workload distribution. The horizontal growth scalability is dependent on the database I/O intensity. The best implementation is the separation of the interactive application from the corresponding data while maintaining the batch application on the same server as the batch data. There are techniques available which transparently manage the batch job submission to the database server.

**High Availability:** OptiConnect for OS/400 can be used to construct highly available solutions. Single-system high availability has an upper limit at the point of failure of that system. However, multiple systems connected together can be used to achieve levels that approach continuous availability. OptiConnect for OS/400 includes a set of Application Program Interfaces (API's) that allow application programs access to the high-speed bus transport. These APIs are intended for use by iSeries 400 Business Partners in the development of high availability solutions. For more information about these APIs, see the **Programming** topic in the iSeries 400 Information Center. Applications providing database mirroring using the OptiConnect connections are available from iSeries 400 Business Partners.

---

### What is OptiConnect?

OptiConnect is the iSeries 400 system area network that provides high-speed interconnectivity between multiple iSeries 400 systems in a local environment. Along with WAN and LAN technologies, OptiConnect provides the high-speed connectivity between cluster nodes in iSeries 400 cluster environments. Technology offered with OptiConnect include the following:

1. HSL OptiConnect using HSL Loop technology
2. Virtual OptiConnect using memory to memory communications available with logical partitioning
3. SPD OptiConnect using the SPD bus hardware

All three OptiConnect technologies require OptiConnect for OS/400 software. This software provides the following functions:

- Additions to OS/400 that provide fast path Distributed Data Management (DDM) access across the high speed interface
- A connection manager that manages OptiConnect resources
- An agent job that runs on the server on behalf of client requests
- Additional OS/400 objects that support and control the connection manager and agent jobs

**Note:** OptiConnect for OS/400 software provides the functions to allow systems to communicate efficiently. A single OptiConnect for OS/400 feature can enable all three OptiConnect technologies (or each individually), provided that the iSeries 400 model supports the capability.

### OptiConnect Hardware Requirements

OptiConnect hardware requirements are dependent on the technology used:

- **HSL OptiConnect:** On models supporting the High Speed Link, there is no additional hardware required other than standard HSL cables to connect the system into the HSL Loop.
- **Virtual OptiConnect:** In a logical partitioning environment, there is no additional hardware required since the connectivity between logical partitions is internal to the system.
- **SPD OptiConnect:** On models supporting the SPD system bus, OptiConnect Receiver cards are installed in a dedicated I/O expansion unit hub, each connecting to a satellite system using standard system bus SPD fibre-optic cables.

All OptiConnect technologies allow iSeries 400 applications to perform inter-system database accesses across a high-performance interface. The ability to efficiently read and update data on connected systems provides the following benefits:

- Multiple client systems can easily and efficiently access databases on a serving system by splitting the processor load for an application across client and server systems.

The client system runs the non-database portion of an application, and the server runs the database activity. Multiple systems provide greater total processing capacity for database access than what a single server can achieve. OptiConnect allows this increased capacity by decreasing processor load and using high-speed connections.

- Customer environments with multiple databases (or databases which can be partitioned into multiple databases) can extend the client/server database model to have multiple serving systems. Applications can access all the databases across OptiConnect connections regardless of the database location.

Ideally, applications and users are assigned to the server that has the data that they use most heavily. Less heavily used data can reside on any of the other systems. This allows you to spread applications to achieve the best balance and throughput.

- Duplication of databases can be eliminated to decrease response time. For example, if you currently maintain copies of data on several systems, you can connect the systems to achieve consistent response time. All applications can access and update one single database.

- OptiConnect functions can be used to duplicate copies of a database and update the duplicated data more efficiently.

## How does OptiConnect Work?

The OptiConnect system area network connects multiple cluster nodes, either unique systems or partitions, using one of the three high-speed technologies available on the iSeries 400. The mechanism used by OptiConnect software to access database files on other systems is modeled after the mechanism used by Distributed Data Management (DDM). DDM uses a DDM file and advanced program-to-program communications (APPC) to redirect file access operations to another system. Similarly, OptiConnect uses DDM files and a special transport service to redirect file access operations to other systems in an OptiConnect network. Thus, OptiConnect can achieve transport efficiencies that are not possible with a more general purpose, wide-area, communications protocol.

Two things differentiate OptiConnect from traditional communications based distributed operations. The first is a high-speed connection mechanism that takes advantage of the i/o bus structure or the memory to connect multiple systems or partitions. The second is an I/O driver that is embedded in the operating system. This driver streamlines the application access to data on a remote system. To accomplish this, SPD OptiConnect provides a shared bus on which systems communicate using a peer-to-peer protocol. With HSL OptiConnect, multiple systems can reside on a single HSL Loop. Much of the APPC protocol stack is bypassed, once OptiConnect establishes system connections. The OptiConnect fast-path connection for database transactions provides DDM access to databases anywhere in the OptiConnect cluster at a fraction of the standard communications code path. Data warehouse, Distributed Relational Database Architecture™ (DRDA), and data propagation functions can use this technology.

## HSL OptiConnect

HSL OptiConnect is a system area network that provides high-speed, point-to-point connectivity between cluster nodes by using HSL Loop technology. Introduced in V4R5 as the high speed replacement for the SPD bus, HSL OptiConnect is supported on V5R1 hardware models. The hardware of the V4R5 models 830 and 840 can be upgraded to support HSL OptiConnect.

The hardware consists of 3, 6, and 15 meter copper HSL cables, used to connect I/O towers to iSeries 400 models 840, 830, 820, and 270 model systems. HSL OptiConnect uses the HSL Loop structure to connect systems together. Of every pair of HSL ports, half of them may be used for HSL OptiConnect, as shown in the following diagram.

Table 1. HSL Loop port availability for HSL OptiConnect

System model	HSL Loop ports available for HSL OptiConnect								Total HSL Loops	Total HSL Opticonnect Loops
	A0-A1	B0-B1	C0-C1	D0-D1	E0-E1	F0-F1	G0-G1	H0-H1		
840	A or B ports		C or D ports		E or F ports		G or H ports		8	4
830	1 of these ports		1 of these ports		N/A <sup>1</sup>	N/A	N/A	N/A	4	2
820	A port	N/A	N/A	N/A	N/A	N/A	N/A	N/A	1	1
270	A port	N/A	N/A	N/A	N/A	N/A	N/A	N/A	1	1

1. Not Available

The following figure shows two systems that are connected via an HSL loop. When OptiConnect for OS/400 is installed, this loop becomes an HSL OptiConnect connection. Two systems can have more than one HSL loop that connects them together, providing the system model supports more than one loop.

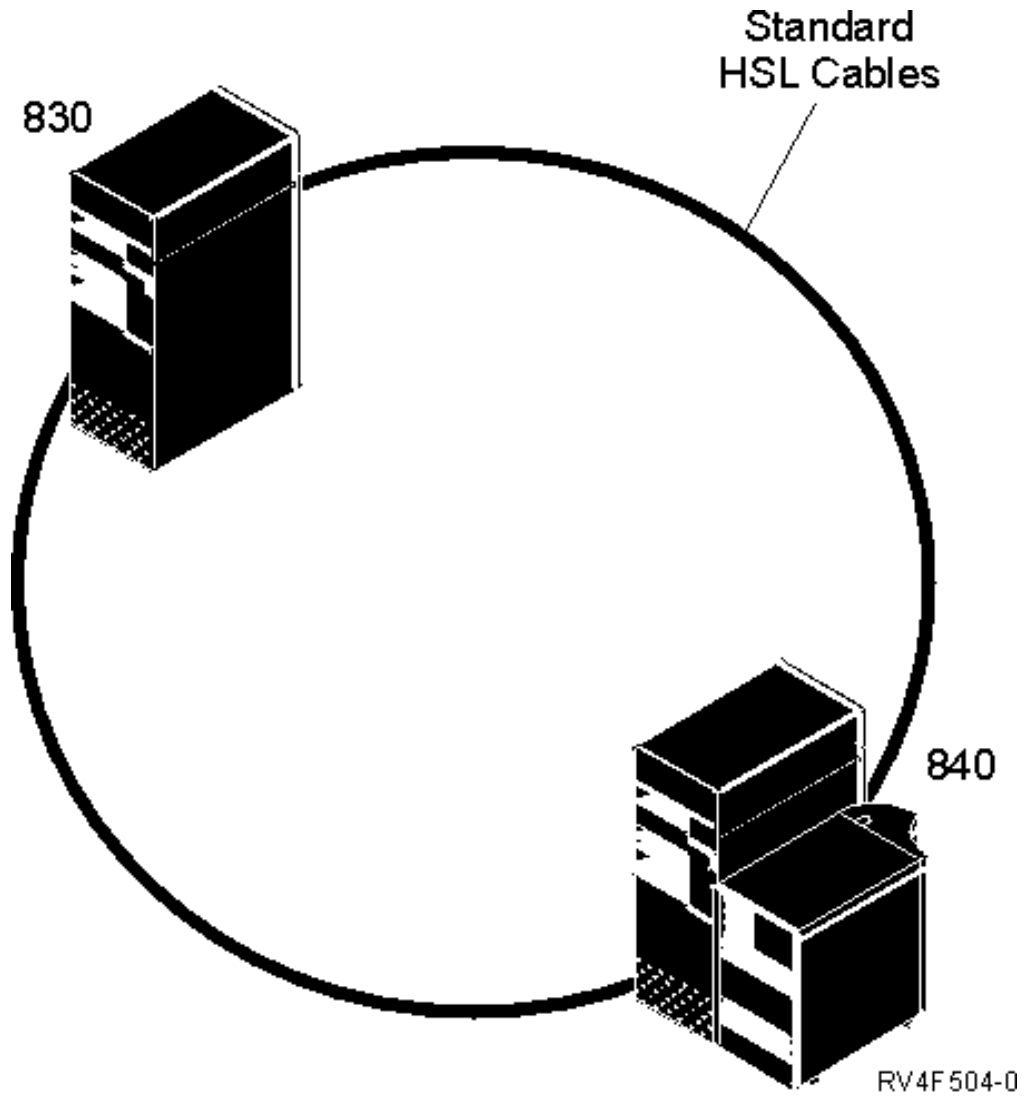

## HSL OptiConnect Example

Figure 1. HSL OptiConnect

### Virtual OptiConnect

OptiConnect for OS/400 software supports virtual OptiConnect, which is a high-speed internal link between LPAR partitions. This is accomplished by partitioning a single iSeries 400 into multiple virtual machines. Each partition has its own address space, instance of OptiConnect, and may have its own dedicated I/O adapters. In addition, each partition appears to TCP/IP as a distinct iSeries 400.

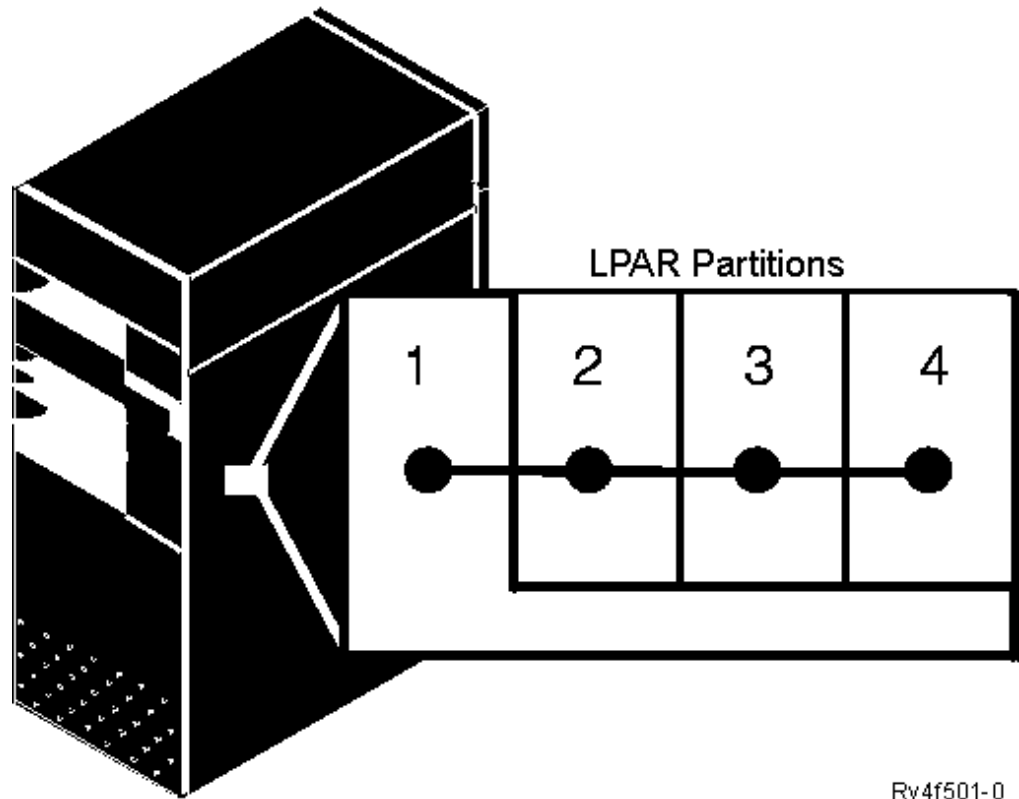

Rv4f501-0

## Virtual OptiConnect

Figure 2. Virtual (inter-partition) OptiConnect

Virtual OptiConnect, in addition to providing a high-speed interconnection between partitions, will allow each partition to participate as a cluster node in a HSL OptiConnect and SPD OptiConnect system area network. In a SPD OptiConnect environment, each partition requires a separate SPD bus, complete with the proper SPD fiber-optic cables and OptiConnect Receiver card in the Hub tower. In a HSL OptiConnect environment, each partition can operate uniquely across a single, shared HSL OptiConnect Loop port.

## SPD OptiConnect

An SPD OptiConnect cluster consists of a collection of systems, each of which dedicates an SPD system bus to connect to a common or shared bus. The system that provides this shared bus is referred to as the **SPD OptiConnect Hub System**. The systems that attach to this shared bus are referred to as **SPD OptiConnect satellite systems**.

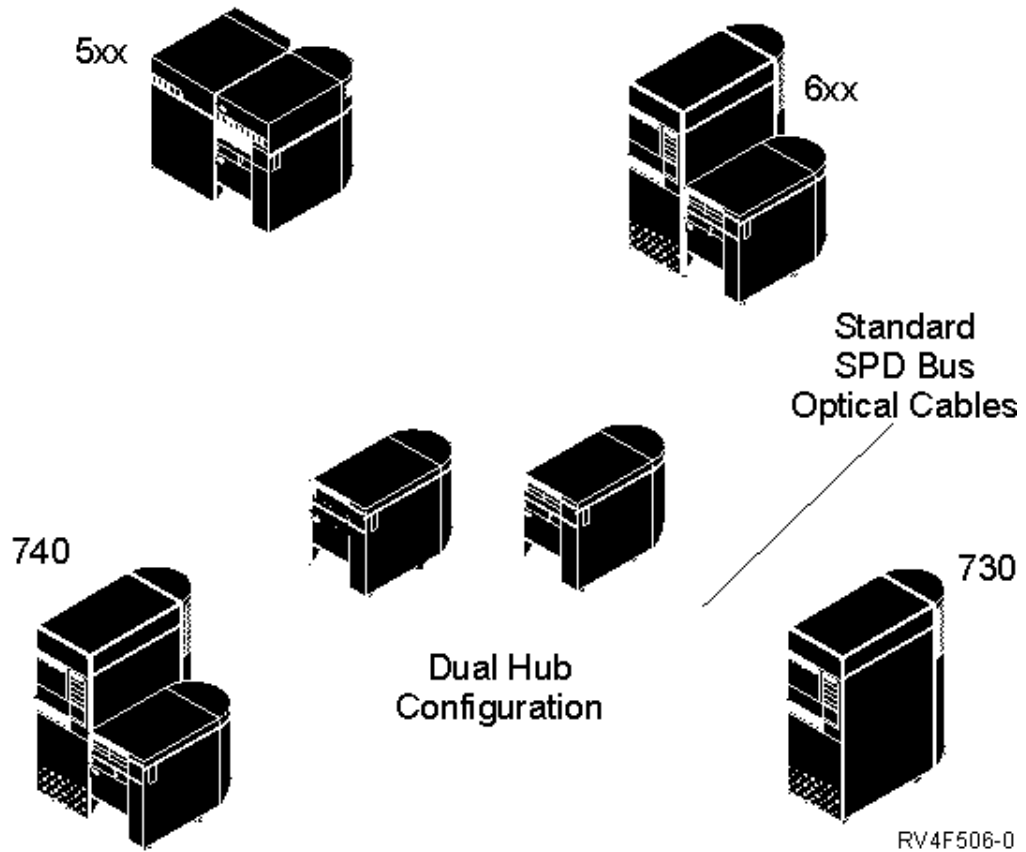

## SPD OptiConnect

Figure 3. SPD OptiConnect

The SPD OptiConnect hub system is the owner of a dedicated I/O expansion unit where OptiConnect Receiver cards are located. This expansion unit provides a total of 13 slots which must be dedicated to OptiConnect Receiver cards. Fiber-optic cables link each OptiConnect Receiver card to a dedicated bus port on a satellite system. This enables all systems in the cluster to communicate with other systems on the shared bus.

Figure 3 shows a dual bus configuration, providing full redundancy in the SPD OptiConnect system area network. If one of the hub systems fail, the cluster remains up, and all communications activity is run through the remaining hub. When both hubs are operating, the communications traffic is shared between both. This increases the bandwidth with two paths available for use.

An SPD OptiConnect network can consist of up to 14 systems (one hub and 13 satellites) with full system-to-system connectivity. A satellite system can communicate with both hub systems and all satellite systems on the same shared bus. Interoperability between OS/400 versions is maintained so that systems at different release levels can be connected in the same SPD OptiConnect network. With additional hubs, up to 32 systems can be supported.

## Mixed Technology Environments

Maintenance of a highly available iSeries 400 cluster demands that cluster node additions or removals be made without losing the availability of the cluster to the end user. This requirement applies to the three OptiConnect system area network technologies and for the migration from SPD to HSL systems. The server models that support HSL Loop and HSL OptiConnect technologies have the ability to also support the SPD Bus and SPD OptiConnect technologies by attaching a migration tower. Migration towers allow 8xx and 270 model systems to be added as cluster nodes in a SPD OptiConnect environment.

The iSeries 400 840 and 830 model systems can participate as cluster nodes in both SPD and HSL OptiConnect environments, as shown below. However, the migration tower attached to the system cannot be on the HSL loop used for HSL OptiConnect. Models that do not support more than one HSL Loop cannot participate in both HSL and SPD OptiConnect environments.

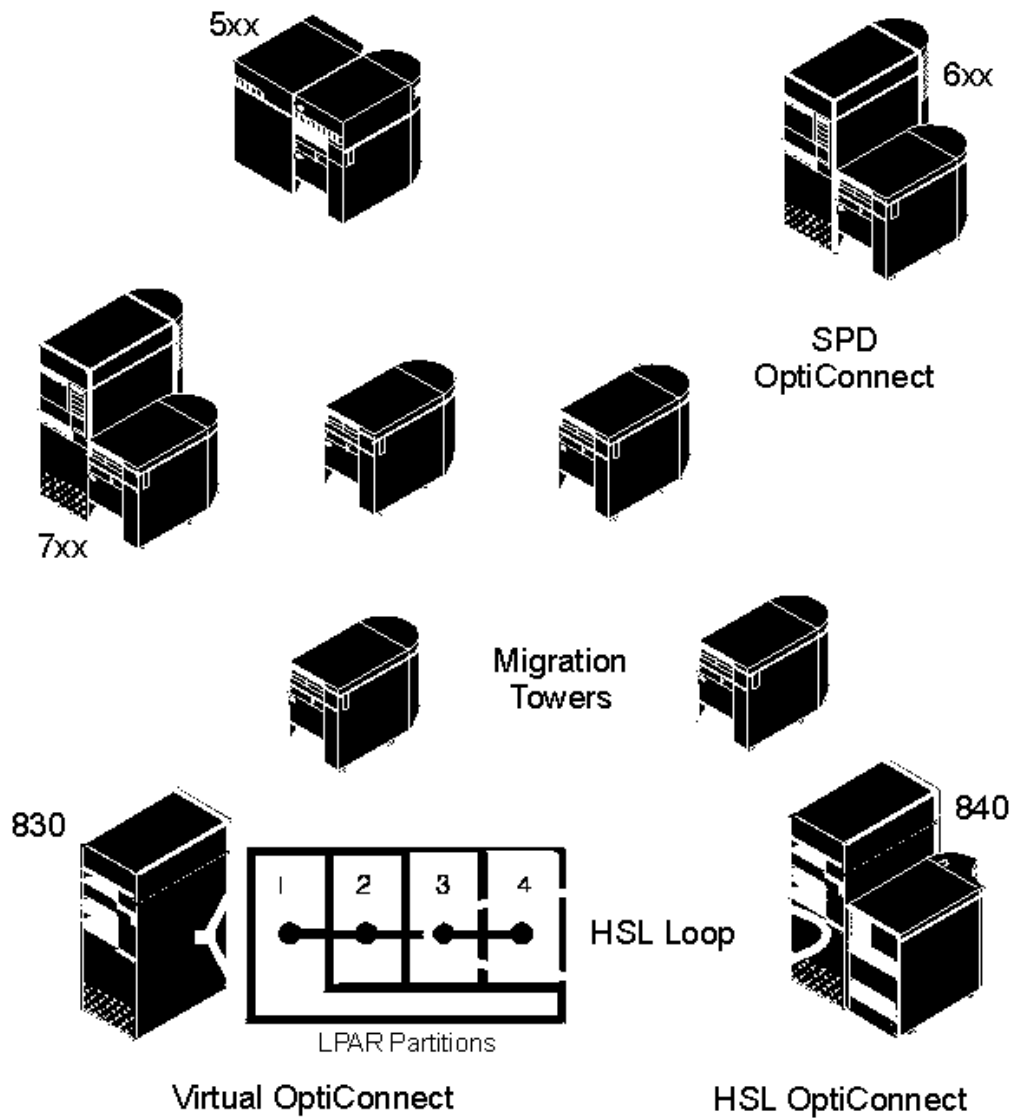

RV4F502-0

## OptiConnect Interoperability

Figure 4. OptiConnect interoperability

### OptiConnect/400 Capabilities

- Distributed Data Management (DDM)  
All Distributed Data Management (DDM) operations for supported object types can run across OptiConnect, including data files, data areas, and data queues.
- Distributed Relational Database Architecture (DRDA)  
OptiConnect supports Structured Query Language (SQL) applications by using the Relational Database Directory to control access to databases on remote systems.

- DB2<sup>®</sup> Multisystem for OS/400  
DB2 Multisystem with its DB2/400 support for multi-node files will run across OptiConnect, providing data warehouse functions of Query/400 support and two-phase commit.
- ObjectConnect/400  
ObjectConnect/400 will operate over OptiConnect to provide high-speed, system-to-system Save/Restore. For more information, see the *Backup, Recovery, and Availability* articles in the *iSeries Information Center*, which is available at <http://www.ibm.com/eserver/series/infocenter>.
- Standard APPC Conversations  
Standard APPC Conversations are available over OptiConnect with an OptiConnect communication controller. For more information, see the *APPC Programming* book for more information.
  - OptiConnect controller type \*OPC support
  - Two-phase commit
  - Multiple mode support
- System Network Architecture Distribution Services (SNADS)  
This allows for SNADS, display station pass-through, network printer pass-through, and other functions across OptiConnect. See the *SNA Distribution Services* book for more information.
- Socket Support  
This function allows applications that utilize Transmission Control Protocol/Internet Protocol (TCP/IP) to communicate over OptiConnect when running in an iSeries 400 cluster with SPD OptiConnect, HSL OptiConnect, or logical partitioning environment.
- Products are available from iSeries 400 Business Partners that provide efficient database mirroring for OptiConnect clusters.



---

## Chapter 2. OptiConnect Requirements

This chapter describes the requirements needed for software and hardware, and how to verify system-to-system connections.

---

### Software Requirements

To plan and install OptiConnect on your AS/400s you need to make sure that you have the correct software and hardware information. OptiConnect for OS/400 software is a priced feature of OS/400.

**Note:** You can either install the hardware or software first, depending on what is most convenient for you.

Additional information:

- Reference Informational RPQ 843871.
- Reference System Cabling Information RPQ 841958.
- Additional information is listed in the Bibliography.

---

### Installing OptiConnect

To install OptiConnect for OS/400:

1. Sign on to the system as the security officer (QSECOFR).
2. Enter:  
GO LICPGM  
  
Press the Enter key.
3. Select option 11 (Install licensed programs) from the Work with Licensed Program display and press the Enter key. The Install Licensed Programs display is shown.
4. Type a 1 next to product option 23 for OptiConnect. Then, press Enter.

When you install OptiConnect, library QSOC is installed on AS/400. For more information on this library, see "QSOC Subsystem" on page 20.

Optional features of OS/400 that you may install are considered to be additional licensed programs. For more information on this installation procedure, see the chapter on installing additional licensed programs in the *Software Installation* book.

If you need to remove OptiConnect from your system, use the Delete Licensed Program (DLTLICPGM) command. You can back up the licensed program by using the Save Licensed Program (SAVLICPGM) command.

To find out how to save a copy of your system, see the *Backup, Recovery, and Availability* articles in the *iSeries Information Center*, which is available at <http://www.ibm.com/eserver/iseres/infocenter>.

---

## Hardware Requirements

The tables below show SPD and HSL OptiConnect hardware RPQs and Feature Codes. Refer to them to ensure that you have the necessary hardware requirements before installing OptiConnect.

Table 2. Hardware Required for SPD OptiConnect System

RPQs and Feature Codes	Type	Description
Feature Code 2685: 1063Mbps OptiConnect Receiver card	2685	This RISC card is placed in the Hub system dedicated I/O expansion unit, and connects to a RISC satellite system across fiber-optic cables to a maximum of 500 meters.
Feature Code 2683: 266Mbps OptiConnect Receiver card	2683	This RISC card is placed in the Hub system dedicated I/O expansion unit, and connects to a RISC satellite system across fiber-optic cables to a maximum of 2 kilometers.
Feature Code 2669: Shared Bus Interface card	2669	This CISC card is placed in the Hub system dedicated I/O expansion unit, and connects to a CISC satellite system across fiber-optic cables to a maximum of 2 kilometers.
Feature Code 2688: Optical Link (1063Mbps) card	2688	This RISC card connects a RISC Satellite system to a 1063Mbps OptiConnect Receiver card, type 2685.
Feature Code 2686: Optical Link (266 Mbps) card	2686	This RISC card connects a RISC Satellite system to a 266Mbps OptiConnect Receiver card, type 2683.
Feature Code 0366: 20 meter RISC fiber-optic cable	--	This 20 meter cable connects the 2686 or 2688 card in the RISC satellite system to the 2683, or 2685 card in the hub system dedicated I/O expansion unit.
RPQ 843826: 20 meter CISC fiber-optic cable	--	This 20 meter cable connects the Shared Bus interface card in the CISC satellite system to the 2669 card in the hub system dedicated I/O expansion unit.
RPQ 841958: System Cabling Information	--	This informational RPQ provides system bus cabling information for RISC and CISC systems.
RPQ 843871: OptiConnect Information RPQ	--	This informational RPQ provides OptiConnect configuration and planning information.

Table 3. Hardware Required for HSL OptiConnect System

Feature Codes	Description
Feature Code 1460	3m Copper HSL Cable
Feature Code 1461	6m Copper HSL Cable
Feature Code 1462	15m Copper HSL Cable

---

## SPD OptiConnect Configurations

See Figure 5 on page 13 for an example of a single-hub SPD OptiConnect cluster.

### Hub 1

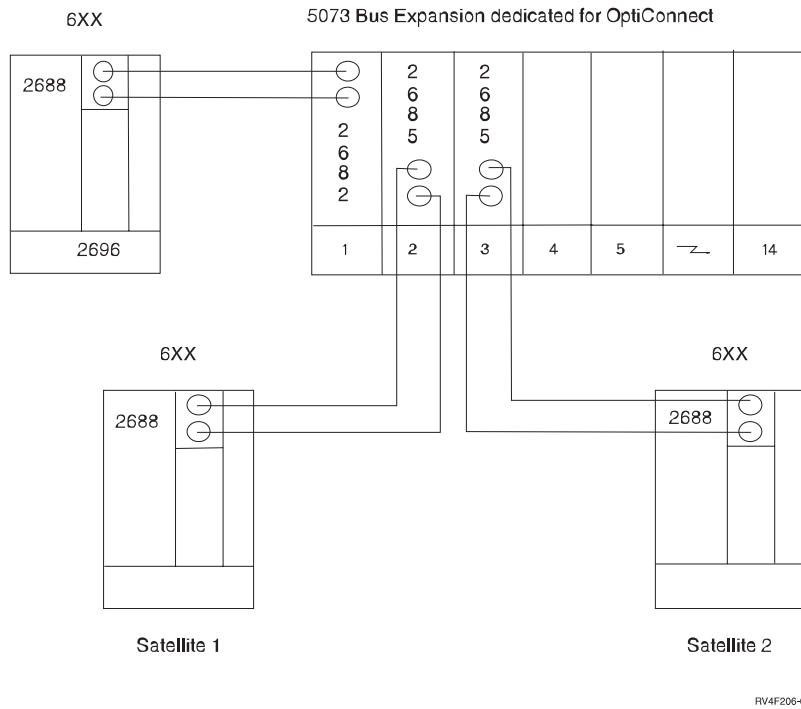

Figure 5. Single-Hub SPD OptiConnect Cluster

### Hardware requirements for a three-system, single-hub SPD OptiConnect cluster

#### Hub-6XX:

- Feature Code 5073 - Qty 1 (System I/O Expansion Unit)
- Feature Code 2685 - Qty 2 (1063Mbps OptiConnect Receiver card)
- Cables - Qty 4 (20 meter RISC fiber-optic cable)

#### Satellite 1 - 6XX:

- Feature Code 2688 - Qty 1 (Optical Link (1063Mbps) card)

#### Satellite 2 - 6XX:

- Feature Code 2688 - Qty 1 (Optical Link (1063Mbps) card)

An example of a dual-hub OptiConnect cluster is shown in Figure 6 on page 14.

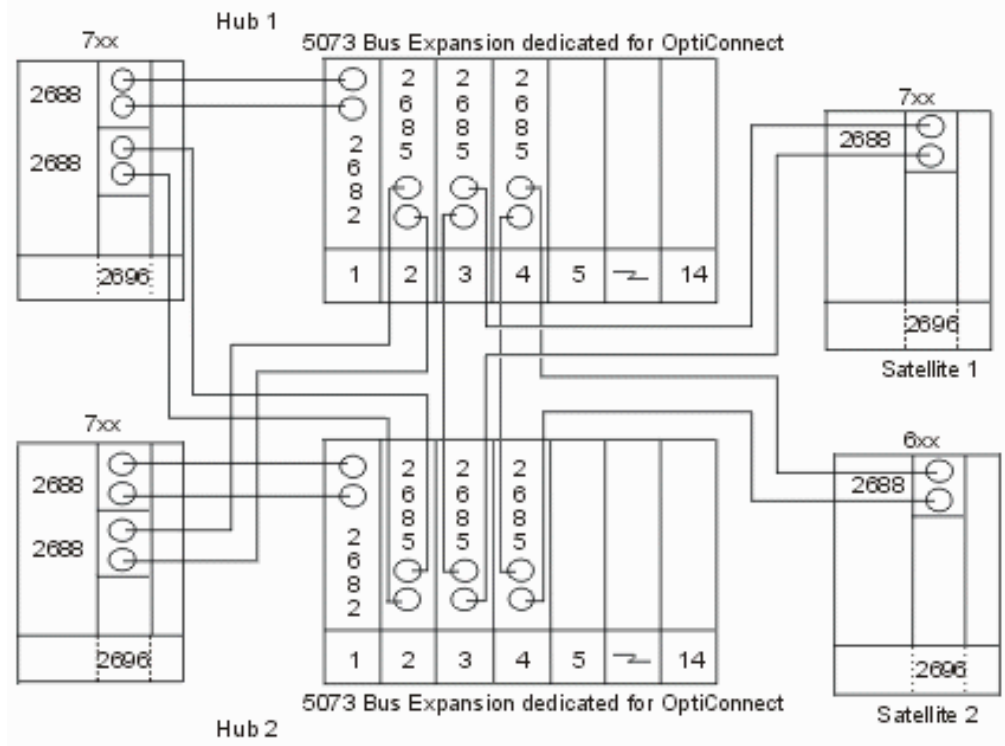

Figure 6. Dual-Hub SPD OptiConnect Cluster

**Hardware requirements for a four-system, dual-hub SPD OptiConnect cluster**

**Hub 1 - 6XX:**

- Feature Code 5073 - Qty 1 (System Unit Expansion Tower)
- Feature Code 2685 - Qty 3 (OptiConnect Receiver (1063Mbps) card)
- Feature Code 2688 - Qty 1 (Optical Link Processor (1063Mbps) card)
- Cables - Qty 5 (20 meter RISC fiber-optic cable)

**Hub 2 - 6XX:**

- Feature Code 5073 - Qty 1 (System Unit Expansion Tower)
- Feature Code 2685 - Qty 3 (OptiConnect Receiver (1063Mbps) card)
- Feature Code 2688 - Qty 1 (Optical Link Processor (1063Mbps) card)
- Cables - Qty 5 (20 meter RISC fiber-optic cable)

**Satellite 1 - 6XX:**

- Feature Code 2688 - Qty 1 (Optical Link Processor (1063Mbps) card)

**Satellite 2 - 6XX:**

- Feature Code 2688 - Qty 1 (Optical Link Processor (1063Mbps) card)

**Note:** The external bus used for SPD OptiConnect on a satellite system must be the odd bus if the other bus on the Optical Link card is used to connect to a non-OptiConnect tower. If configured the other way around, and the satellite system is started while the hub system is powered off, the other bus will configure in as the even bus. This may result in problems when the hub system is powered up.

---

## Verifying Installation

To ensure that the OptiConnect code and objects have been installed correctly, run the Check Product Option (CHKPRDOPT) command.

Follow the steps below to verify a successful installation:

1. Start the OptiConnect subsystem. Enter the following command on all systems:

```
STRSBS QSOC/QSOC
```

2. Check the operator messages for the messages that were issued when QSOC subsystem was started. Enter the following command on all systems:

```
DSPMSG *SYSOPR
```

The following messages should appear after a successful initiation of the OptiConnect Connection Manager:

```
Subsystem QSOC in library QSOC starting.  
Subsystem QSOC started.  
OptiConnect connection manager started at mm/dd/yy hh:mm:ss.  
OptiConnect connected to SYSTEMA using SOC01 at mm/dd/yy hh:mm:ss.  
OptiConnect connected to SYSTEMB using SOC02 at mm/dd/yy hh:mm:ss.
```

The number of messages (and adapter types within the messages) you see depend on the following:

- Your hardware configuration
  - The systems to which you are connected
  - The systems that have started the OptiConnect subsystem
3. Enter the command VFYOPCCNN from the command line  
This begins the installation verification. It ensures system-to-system connection within the cluster. Check your joblog for the completion message.

```
OptiConnect verification test completed with no errors.
```

4. Use the Work with OptiConnect Activity (WRKOPCACT) command to check the OptiConnect activity on the systems in the cluster. Enter:

```
QSOC/WRKOPCACT
```

You should see activity as a result of the Verify OptiConnect Connection (VFYOPCCNN) procedure. VFYOPCCNN causes the system to act as a *client* to each of the other systems in the network. See “Work with OptiConnect Activity (WRKOPCACT)” on page 25 for more information on how to use this command.

5. To confirm that the hardware connections are operational and show the operational status of the bus receiver cards, enter:

```
WRKHDWRSC TYPE(*CSA)
```

The Work with Hardware Resources (WRKHDWRSC) command TYPE(\*CSA) displays a resource for each remote system that had, at some point, an operational connection to the system on which you are entering the command. See “Work with Hardware Resources” on page 35.



---

## Chapter 3. Understanding the OptiConnect Environment

---

### SPD OptiConnect Terminology

A SPD OptiConnect network is a collection of AS/400 systems that are connected through dedicated system buses by using fiber-optic cables. The systems in a SPD OptiConnect cluster share a common external optical system bus that is located in an expansion unit or frame. The system that provides this system bus is called the **hub** system. The hardware used to create a hub system for a SPD OptiConnect cluster consists of a dedicated system I/O expansion unit or frame. Each system that plugs into this bus with an OptiConnect Receiver card is called a **satellite** system. Each satellite system dedicates one of its external system buses to connect to the receiver card in the hub system's expansion unit or frame.

The SPD OptiConnect **link** refers to the fiber-optic cable that connects a system to the shared bus. The SPD OptiConnect **path** refers to the logical relationship between each pair of systems in the cluster. There are two levels of redundancy available to the SPD OptiConnect cluster: **link redundancy** and **path redundancy**.

**Link redundancy** is achieved by linking systems together via fiber-optic cables. Every Optical Link card has two external optical bus ports that are cabled to the ports in the SPD OptiConnect receiver card. If an Optical Link card is connected to two separate bus receiver cards, then a third cable connects these two cards. If the primary cable for a bus fails, the Optical Link card will detect the failure. It will then route subsequent bus traffic across the other cable or cables. This feature is standard for all SPD OptiConnect systems that are attached to the OptiConnect hub. Bus performance and availability is degraded for both buses until the failing link has been restored.

The second level of redundancy available to the SPD OptiConnect cluster is **path redundancy**. Configuring two hub systems can establish path redundancy in the SPD OptiConnect cluster. Each satellite uses one bus to connect with one hub system, and another bus to connect to the other hub system. The OS/400 infrastructure automatically detects that two buses are available, and during normal communications, both buses will be used. In the case of a communication failure the remaining bus picks up all of the communication traffic.

**Note:** There is a limitation to the recovery capability of this configuration when processing some types of transactions. If a bus/link/adaptor fails when this type of transaction is in flight, the alternate bus cannot be used to recover. In this case, the job will receive a communication error. See "Appendix A. Messages" on page 67 for more information about communications messages.

Link redundancy is standard for all SPD OptiConnect buses. The customer can order path redundancy. An extra set of OptiConnect Receiver cards, and either an extra I/O expansion tower or frame will be required, along with another set of cables.

**Note:** Systems attached to the hub system do **not** use the hub system's CPU resources.

---

## HSL OptiConnect Terminology

An HSL OptiConnect system area network is a collection of systems that are connected on a single HSL Loop. An HSL Loop consists of two HSL strings that are connected together. Each HSL string operates in full duplex mode. When connected, the system determines the mid-point of the HSL Loop and operates as two strings. When a failure in the loop occurs, the two remaining strings continue to operate with the longer loop picking up the additional towers or systems that went with the other string prior to the break.

Each system supporting HSL Loop technology has at least two HSL ports that can be used to operate a HSL string or paired together to operate as a single HSL Loop. For reliability, it is suggested that you pair all HSL strings and use them as HSL Loops. This pairing is pre-determined with HSL Port A0 with HSL Port A1, and so forth.

**Note:** There is no additional hardware required to operate an HSL Loop as an HSL OptiConnect environment.

---

## Application Structure

An OptiConnect cluster will usually have a database system and one or more application systems. The system where the database resides is the **database** system, and the systems that contain the applications are called **application** systems. The OptiConnect software allows a program on the application system to make database changes or database queries on the database system. Central Processing Unit (CPU) work load ratios of under 30% database and 70% application will benefit the most by distributing work loads between systems in the OptiConnect network. Figure 7 illustrates an example of this type of setup.

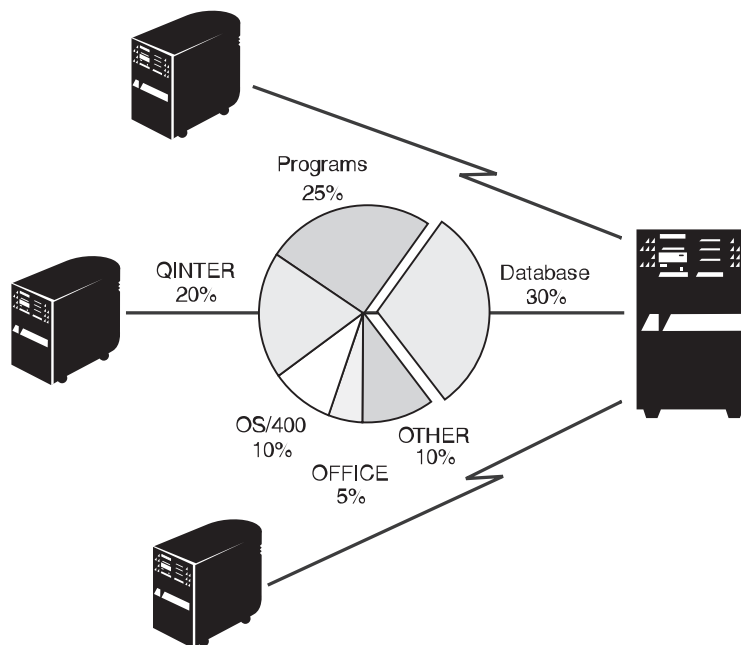

RV4F201-0

Figure 7. CPU Utilization by OptiConnect for OS/400

Another important consideration is whether the application is batch or interactive. This clustering technology is optimal for interactive workloads. Batch workloads require special considerations and may not be appropriate for use in an OptiConnect environment. However, solutions can be designed to effectively handle a mixture of batch and interactive workloads, as well as multiple database and application methods. Applications with heavy database activity and large numbers of file Open and Close operations, may not realize the full potential of the OptiConnect technology.

When a program opens a database file, the associated DDM file or RDB entry identifies the database system name. The OptiConnect Connection Manager on the application system sends the database request to the database system by using a fast *device driver*. The OptiConnect communication link provides access at a fraction of the DDM system overhead because its communications protocol operates only in a specific shared bus environment. The OptiConnect Connection Manager connects the request with an agent job on the database system. Agent jobs work with the database code to issue the request and route the result back to the application system.

---

## OptiConnect Components

The following list outlines the basic required components of OptiConnect. They should not be deleted for any reason.

### Library

The QSOC library holds all the objects that are used by OptiConnect:

- Programs
- Files
- Classes
- Commands
- Data areas
- Panel groups
- Subsystem Description
- Product loads
- Job Queue
- Job descriptions

### Subsystem

The OptiConnect connection manager jobs and agent jobs run in the QSOC subsystem unless a mode table has been configured to run under a different subsystem. See “Use of Mode Tables” on page 52.

### Jobs

OptiConnect has two kinds of jobs: The OptiConnect Connection Manager job (SOCMGR) and the agent jobs (SOCAnnnnnn). The SOCMGR job manages OptiConnect resources. There is one SOCMGR job per system. The SOCAnnnnnn job (agent) interfaces with the database on behalf of the application system. Each of the agent jobs is a data access job that works to get data to and from the remote system.

### Job Descriptions

There are three job descriptions for OptiConnect: QYYCMGR, QYYCDTSU, and QYYCSRA. QYYCMGR is the job description for the SOCMGR job. QYYCDTSU is the job description for all SOCAnnnnnn jobs. QYYCSRA is the

job description for the ObjectConnect Save/Restore agent jobs. These job descriptions are shipped as part of OptiConnect.

#### **Job Queue**

The QSOC job queue is used to submit OptiConnect jobs to the QSOC subsystem.

#### **Autostart job**

The SOCMGR job is automatically started when the QSOC subsystem is started.

#### **User Profile**

The OptiConnect Connection Manager job runs under the QSOC user profile. The OptiConnect agent jobs run under QUSER user profile and can be changed through the QYYCDTSU job description. The agent job's authority and library list can also be changed through the job description QYYCDTSU. See "Customizing OptiConnect" on page 44.

#### **Routing Entries**

The routing entries used in starting subsystem jobs have compare values of QYYCDTSU, QYYCMGR, QYYCSRA, and QZDMAGNT.

#### **Commands**

OptiConnect commands are:

- **WRKOPCACT** (Work with OptiConnect Activity): Displays information on the number of transactions and number of bytes that are read and written for both application and database systems. It also provides information about the connection status to other systems.
- **DSPOPCLNK** (Display OptiConnect Link Status): Shows pertinent link information about multiple systems that are connected using the fiber-optic bus or HSL environment.
- **VFYOPCCNN** (Verify OptiConnect Connection): Runs the OptiConnect Installation Verification process. See "Verifying Installation" on page 15.

---

## **QSOC Subsystem**

The OptiConnect system jobs, as delivered by IBM®, are set up to run in the QSOC subsystem. You can find a description of the QSOC subsystem in the QSOC library. To view the description, enter the following Display Subsystem Description (DSPSBSD) command:

```
DSPSBSD (QSOC/QSOC)
```

The subsystem description contains information on many items. The following information pertains specifically to the OptiConnect operating environment:

- **Autostart job entries**

Autostart job entries list jobs that are initiated when the subsystem is started. An autostart job is defined for the QSOC subsystem and runs when the subsystem is started. This job initiates the OptiConnect Connection Manager job, SOCMGR. When you choose option 3 on the Display Subsystem Description display, you receive a display that lists the autostart entries. Figure 8 on page 21 shows an example of the Display Autostart Job Entries screen.

```

Display Autostart Job Entries
Subsystem description:  QSOC          Status:  Active          System:  SYSTEMA
Job      Job Description  Library
SOCMGR   QYYCMGR          QSOC

```

Figure 8. Display Autostart Job Entries

- **Job queue entries**

You can display the job queue entries by choosing option 6 on the Subsystem Description display. The Display Job Queue Entries display shows the queues from which jobs are taken when a given subsystem is run. Figure 9 shows an example of the job queue entries that are defined in the QSOC subsystem.

```

Display Job Queue Entries
Subsystem description:  QSOC          Status:  Active          System:  SYSTEMA
Seq  Job      Max -----Max by Priority-----
Nbr  Queue   Library Active 1  2  3  4  5  6  7  8  9
10   QSOC    QSOC  *NOMAX * * * * * * * * *

```

Figure 9. Display Job Queue Entries

- **Routing entries**

You can display the routing entries detail by choosing option 7 on the Subsystem Description display. Figure 10 on page 22 is an example of a Display Routing Entry Detail display which shows a compare value of QYYCDTSU. This value is matched against the routing data field in the job description that is placed in the job queue for this subsystem. When the job is pulled off the job queue, the routing data is compared to all of the routing entries in the subsystem. When a match is found, the program that is listed for the routing entry is run. The program is run using the class that is specified for that job.

```

                                Display Routing Entry Detail
                                System: SYSTEMA
Subsystem description:  QSOC           Status:  Active

Routing entry sequence number . . . . . : 10
Program . . . . . : QYYCDTSU
  Library . . . . . : QSOC
Class . . . . . : QYYCAGNT
  Library . . . . . : QSOC
Maximum active routing steps . . . . . : *NOMAX
Pool identifier . . . . . : 1
Compare value . . . . . : 'QYYCDTSU'

Compare start position . . . . . : 1

                                Bottom

Press Enter to continue.

F3=Exit   F12=Cancel   F14=Display previous entry

```

Figure 10. Display Routing Entry Detail

Each entry on this display is described in detail in the *Work Management (SC41-5306-03)* book.

---

## OptiConnect Job Descriptions

The job descriptions for the SOCMGR and SOCA<sup>nnnnnnn</sup> jobs are already defined in the QSOC library when you install OptiConnect. SOCMGR job uses QYYCMGR job description, and the SOCA<sup>nnnnnnn</sup> jobs use QYYCDTSU job description. These job descriptions may be altered to fit the customer environment.

The Connection Manager job, SOCMGR, maintains the agent jobs through the request data in the job description, QYYCMGR. To change this, see “QYYCMGR Job Description” on page 47.

The default value for OptiConnect agent jobs, SOCA<sup>nnnnnnn</sup>, runs under the **QUSER** user profile. See “Changing QUSER Access Authority” on page 45 for more information.

---

## Chapter 4. Managing the OptiConnect Network

This chapter describes the key elements for operating the OptiConnect cluster.

---

### Starting OptiConnect

Starting OptiConnect is initiated by starting the QSOC subsystem. When you start the QSOC subsystem, the OptiConnect Connection Manager, SOCMGR, starts as an autostart job. If prestart agent jobs (SOCAnnnnnn) are defined, they will also start automatically when QSOC subsystem starts.

To start the QSOC subsystem, you must enter the Start Subsystem (STRSBS) command on each system.

```
STRSBS QSOC/QSOC
```

---

### Ending OptiConnect

Because OptiConnect runs under the QSOC subsystem, you can end OptiConnect by shutting down QSOC. Before you end the OptiConnect subsystem on a particular system, you should make sure that there are no OptiConnect application programs that use the connection. See .

If you are using remote journaling over OptiConnect on this system, end it before ending the QSOC subsystem. Remote journal jobs do not get displayed with the Work with Active Jobs (WRKACTJOB) command.

To end OptiConnect, enter the following command:

```
ENDSBS QSOC *IMMED
```

After the ENDSBS command is issued, the time required to end the OptiConnect manager varies with the number of agent jobs to end in the subsystem. See “Tips on Starting and Stopping your System with OptiConnect” for more information on starting and stopping agent jobs. During this time, the QSOC subsystem cannot be restarted.

**Note:** Ending OptiConnect on one system does not affect OptiConnect activity between other systems on the same bus.

---

### Tips on Starting and Stopping your System with OptiConnect

When you stop OptiConnect, you are also stopping any prestarted agent jobs. The more agent jobs, the longer it takes to end QSOC subsystem. Similarly, when starting OptiConnect, the larger the initial number of agent jobs you specified, the longer the subsystem takes to start.

Balancing the number of prestarted agent jobs, and the time the subsystem takes to start or stop, is important. Prestarted agent jobs use resources as the jobs start or end. You must consider how many prestarted agent jobs you may need.

For example, if there are many short transactions, as when retail stores process credit card authorizations, increasing the number of prestarted jobs may be

beneficial. Increasing the number of prestarted jobs also increases the time the subsystem QSOC takes to start. However, prestarted jobs allow you to quickly process the credit card authorizations.

On the other hand, you may have longer or less numerous transactions. For example, when a teller at a bank signs on for the day. In this type of environment, you may decide that less prestarted jobs and a shorter system startup is beneficial.

For more information on how to alter the number of prestarted jobs, see "OptiConnect Performance Factors" on page 49.

Prior to ending the QSOC subsystems, you should vary off the \*OPC controllers and the corresponding controllers on the other system. The ENDSBS QSOC command leaves the controllers in an unusable state that requires the user to vary them off, then on, to activate. If the user varies the controllers off manually, then less processing takes place while ending the subsystem.

---

## Getting Information about OptiConnect Activity

Use the following commands to determine if OptiConnect is active and to obtain information about its resources and components:

**Work with Active Job**  
WRKACTJOB

**Work with OptiConnect Activity**  
WRKOPCACT

**Display OptiConnect Link Status**  
DSPOPCLNK

**Work with Hardware Resources**  
WRKHDWRSC

**Display Hardware Resources**  
DSPHDWRSC

The examples in the following sections demonstrate a four-system, dual-hub configuration. The screens are from SYSTEMA which is one of the hubs or bus-owning systems.

### Work with Active Jobs (WRKACTJOB)

You can see a list of active jobs in the QSOC subsystem and monitor OptiConnect activity by using the Work with Active Jobs (WRKACTJOB) command. This can be helpful in determining the start up parameters that are passed to the OptiConnect Connection Manager. To see the active jobs in the QSOC subsystem, enter:

```
WRKACTJOB SBS(QSOC)
```

If the QSOC subsystem is running, you will see a SOCMGR job. If an agent job has been started, you will see one or more agent jobs (SOCA##### jobs) on the target system. Figure 11 on page 25 shows a sample of the Work with Active Jobs display. As you can see, the (SOCMGR) job is running, as well as one agent job (SOCA000001).

```

Work with Active Jobs
SYSTEMA
12/02/95 15:13:17
CPU % .0 Elapsed time: 00:00:00 Active Jobs 60
Type options, press Enter.
 2=Change 3=Hold 4=End 5=Work with 6=Release 7=Display message
 8=Work with spooled files 13=Disconnect ...

Opt Subsystem/Job User Type CPU % Function Status
- QSOC QSYS SBS .0 DEQW
- SOCA000001 QSOC BCH .0 DEQW
- SOCMGR QSOC ASJ .0 PGM-QYYCMGR DEQW

Bottom

Parameters or command
===>
F3=Exit F5=Refresh F7=Find F10=Restart statistics
F11=Display elapsed data F12=Cancel F23=More options F24=More keys

```

Figure 11. Work with Active Jobs

To determine if agents are active or inactive (prestarted), enter number 5 (Work with) to the left of the job name. Then, choose the option that allows you to view the call stack or view open files. INACTIVE agents are SOCA##### with no open files.

Active agents are often present until one of the following occurs:

- The source system job ends, or the user logs off
- The source system job ends, or the user uses the Reclaim Resources (RCLRSC) command
- The source system job ends, or the user uses the Reclaim DDM Conversations (RCLDDMCNV) command

## Work with OptiConnect Activity (WRKOPCACT)

The Work with OptiConnect Activity (WRKOPCACT) command, allows you to view information about database transactions, fiber-optic bus activity, and connection status for client and server systems. When running this command, three views of the WRKOPCACT display are available. To display the Work with OptiConnect Activity display, enter:

```
WRKOPCACT
```

```

Work with OptiConnect Activity
System:  SYSTEMA
Collection Start Time . . . . . : 15:03:46
Collection End Time . . . . . : 15:54:56
Collection Elapsed Time . . . . . : 00:51:10

Type options, press Enter.
1=Vary on 2=Vary off

  System      Total  Trans   Data  Data  %   Connection
Opt Resource   Trans /Sec  Count Rate Used  Status
  SYSTEMB      8     0     4     1     0  Varied on
    SOC13      0     0     2     1     0  Active
    SOC02      0     0     2     0     0  Active
  SYSTEMC      0     0     1     0     0  Active
    SOC08      0     0     1     0     0  Varied on
    SOC10      0     0     0     0     0  Active
  SYSTEMD      3     0     3     0     0  Varied on
    SOC07      0     0     1     0     0  Active
    SOC04      0     0     2     0     0  Active

Totals          11     0     8     1     0

F3=Exit    F5=Refresh  F13=Reset  F11=Client Statistics View  Bottom
F14=Jobs and Tasks

```

Figure 12. Work with OptiConnect Activity Display

Figure 12 shows an example of the Work with OptiConnect Activity display from the perspective of an *application* system. The screen shows information about the Connection Status and Total Transactions between the system issuing the command, and other systems in the OptiConnect network.

The activity is broken down by individual OptiConnect adapter cards for each system and defined over the collection period. The collection period is shown at the top of the display. To reset the collection data on this display, press F13 (Reset). Using the options listed, you can vary on or vary off the systems or resources shown on this display.

The next display shows this systems activity as a *client*. It can be accessed by pressing the  
F11=Client Statistics View

function key.

```

Work with OptiConnect Activity
System: SYSTEMA
Collection Start Time . . . . . : 15:03:46
Collection End Time . . . . . : 15:54:56
Collection Elapsed Time . . . . . : 00:51:10

Type options, press Enter.
1=Vary on 2=Vary off

System
-----Client Statistics-----
Opt Resource Users Transactions Read(KB) Write(KB)
SYSTEMB 0 3 5 2
SOC13 4 2
SOC02 1 0
SYSTEMC 0 12 1 1
SOC08 1 0
SOC10 0 1
SYSTEMD 0 0 7 0
SOC07 3 0
SOC04 4 0

Totals 0 15 13 3

F3=Exit F5=Refresh F13=Reset F11=Server Statistics View F12=Cancel
F14=Jobs and Tasks
Bottom

```

The next display shows this system's activity as a *server*. It can be accessed by pressing the F11=Server Statistics View

function key.

### OptiConnect Jobs and Tasks

```

Work with OptiConnect Activity
System: SYSTEMA
Collection Start Time . . . . . : 15:03:46
Collection End Time . . . . . : 15:54:56
Collection Elapsed Time . . . . . : 00:51:10

Type options, press Enter.
1=Vary on 2=Vary off

System
-----Server Statistics-----
Opt Resource Agents Transactions Read(KB) Write(KB)
SYSTEMB 1 4 9 2
SOC13 4 2
SOC02 5 0
SYSTEMC 3 10 2 1
SOC08 2 1
SOC10 0 0
SYSTEMD 0 0 6 0
SOC07 3 0
SOC04 3 0

Totals 4 14 17 3

F3=Exit F5=Refresh F13=Reset F11=Main View F12=Cancel
F14=Jobs and Tasks
Bottom

```

The Work with OptiConnect Jobs function, accessible from the F14=Jobs and Tasks function key, allows the user to view a list of OptiConnect jobs and tasks. OptiConnect jobs and tasks have one or more OptiConnect conversations attached. The initial prompt panel, shown in Figure 13 on page 28, allows for the division of

jobs and systems into subsets. If any of the input character strings are ended with an '\*', then that '\*' will be treated as a wildcard.

Work with OptiConnect Jobs		SYSTEMA
Type choices, press Enter.		00/00/00 00:00:00
Job name . . . . .	*ALL	Name, generic*, *ALL
Job user . . . . .	*ALL	Name, generic*, *ALL
Remote job name . . . . .	*ALL	Name, generic*, *ALL
Remote job user . . . . .	*ALL	Name, generic*, *ALL
Remote system . . . . .	*ALL	System, generic*, *ALL
F12=Cancel		

Figure 13. Work with OptiConnect Jobs Display

After the selection information has been entered, the Work with OptiConnect Jobs and Tasks screen is displayed and shows the following information:

- Local Job  
The name of the job or task that exists on the system where WRKOPCACT is run.
- Local User  
The user of the local job. This field is blank if the entry is a task.
- Remote Job  
The name of the job or task that exists on the remote system.
- Remote User  
The user of the remote job.
- Remote Number  
The job number of the remote job.
- Remote System  
The system where the remote job or task exists.

```

Work with OptiConnect Jobs and Tasks                                SYSTEMA
                                                                09/16/98 14:09:54
Type options, press Enter.
 5=Work with Job  9=End Remote Job
Local  Local  Remote  Remote  Remote  Remote
Opt Job   User  Job     User    Number  System
ADMIN  QTMHHTTP ADMIN  QTMHHTTP 058622 SYSTEMA
ADMIN  QTMHHTTP ADMIN  QTMHHTTP 058440 SYSTEMA
ADMIN  QTMHHTTP ADMIN  QTMHHTTP 058437 SYSTEMA
ADMIN  QTMHHTTP ADMIN  QTMHHTTP 058430 SYSTEMA
ADMIN  QTMHHTTP ADMIN  QTMHHTTP 058428 SYSTEMA
ADMIN  QTMHHTTP ADMIN  QTMHHTTP 058622 SYSTEMB
ADMIN  QTMHHTTP ADMIN  QTMHHTTP 058440 SYSTEMB
ADMIN  QTMHHTTP ADMIN  QTMHHTTP 058437 SYSTEMB
ADMIN  QTMHHTTP ADMIN  QTMHHTTP 058430 SYSTEMB
ADMIN  QTMHHTTP ADMIN  QTMHHTTP 058428 SYSTEMB
ADMIN  QTMHHTTP ADMIN  QTMHHTTP 058622 SYSTEMD
ADMIN  QTMHHTTP ADMIN  QTMHHTTP 058440 SYSTEMD
ADMIN  QTMHHTTP ADMIN  QTMHHTTP 058437 SYSTEMD
ADMIN  QTMHHTTP ADMIN  QTMHHTTP 058430 SYSTEMD
More...
F3=Exit  F4=Prompt  F5=Refresh  F11=Display Statistics View  F12=Cancel
F14=Display Jobs Only  F15=Display Tasks Only  F16=Resequence

```

Figure 14. Work with OptiConnect Jobs and Tasks (View 1)

To select an option, type the option number in the **Opt** column and press Enter. The function associated with the selected option will be performed for each of the selected jobs. For more information about the options available, move the cursor to the **Opt** column and press Help. The options are not available for tasks.

**Note:** You may type an option next to one or more job.

You can select the following options:

- 5=Work with Job
 

Use this option to display the Work with Job (WRKJOB) menu. WRKJOB may be used to end the local job, and consequently, the remote job as well. While the jobs are ending, the path status shows close pending (CLSPND). If F13=Reset is pressed after both jobs have ended, the job entry disappears from the list.
- 9=End Remote Job
 

Use this option to run the End Job (ENDJOB) command on the remote system. When the remote job is ended, the path status shows close pending, CLSPND. Local and remote job names remain in the job list entry until the local job either ends, or Distributed Data Management (DDM) conversations are reclaimed. You can reclaim these conversations using the Reclaim DDM Conversations (RCLDDMCNV) command. If RCLDDMCNV is used, the local job will not end, but will be removed from the list once it is refreshed. At this point, it is no longer considered to be an OptiConnect job, although it is still available for other work.

If you press the  
F11=Display Statistics View

function key, Figure 15 on page 30, *Work with OptiConnect Jobs and Tasks* appears.

Work with OptiConnect Jobs and Tasks						SYSTEMA
						09/16/98 16:54:26
Type options, press Enter.						
5=Work with Job 9=End Remote Job						
Opt	Local Job	Local User	Path Status	Transaction Count	Response Time	Data Count
	USRRESTART	QTMHHTTP	IDLE	12	12.00	12
	USRRESTART	QTMHHTTP	IDLE	14	14.00	14
	USRRESTART	QTMHHTTP	BUSY	16	15.00	15
	WEBDY020	QTMHHTTP	IDLE	8	8.00	8
	WEBDY020	QTMHHTTP	BUSY	10	9.00	9
	WEBDY020	QTMHHTTP	IDLE	10	10.00	10
	WEBDY020	QTMHHTTP	BUSY	14	13.00	13
	WEBDY020	QTMHHTTP	IDLE	8	8.00	8
	WEBDY020	QTMHHTTP	BUSY	10	9.00	9
	WEBDY020	QTMHHTTP	IDLE	10	10.00	10
	WEBDY020	QTMHHTTP	BUSY	14	13.00	13
	WEBDY020	QTMHHTTP	IDLE	8	8.00	8
	WEBDY020	QTMHHTTP	BUSY	10	9.00	9
	WEBDY020	QTMHHTTP	IDLE	10	10.00	10

More...

F3=Exit    F4=Prompt    F5=Refresh    F11=Display Remote View    F12=Cancel  
F13=Reset    F14=Display Jobs Only    F15=Display Tasks Only    F16=Resequenece

Figure 15. Work with OptiConnect Jobs and Tasks (View 2)

The display above shows the following information:

- Path Status

Busy: the job or task has at least one outstanding OptiConnect transaction that has not completed.

Idle: there is no outstanding OptiConnect transactions and the job, or task, is not doing any OptiConnect communications work at this time.

CLSPND: an OptiConnect close path is pending and the path, or conversation, is in the process of closing down.

LBUSY: the job or task has at least one outstanding OptiConnect transaction that has not been in that state for more than 10 minutes.

- Transaction Count

The total number of OptiConnect requests that have been initiated since the last WRKOPCACT restart. The transactions count is expressed in individual transactions and is accumulative since either the last time OptiConnect started, or the job and task data collection were reset.

- Response Time

The total time, in seconds, waiting for OptiConnect transactions to complete, divided by the completed transaction count. The completed transaction count is the previously defined transaction count if idle, or the transaction count minus one, if busy. Response time is an average that is measured since the last time OptiConnect started, or the job and task data collection were reset.

- Data Count

The data that is transferred by the job or task in Kilobytes. This figure is accumulative since either the last time OptiConnect started, or the job and task data collection were reset.

**Note:** When one or more remote jobs have been requested to end and F4=Prompt is pressed, then the End Remote OptiConnect Job (OPCJRCF) screen will be displayed for each job. Otherwise, Confirm End of Remote OptiConnect Jobs (OPCECNF) is displayed for a single confirmation.

## Display OptiConnect Link Status (DSPOPCLNK)

To display the connection status information of the links between systems in the HSL or fiber-optic networks, use the Display OptiConnect Link Status (DSPOPCLNK) command. The *Display OptiConnect Link Status* screen will vary depending on your hardware configuration. If your hardware configuration includes HSL OptiConnect, the following screen will appear:

```
Display OptiConnect Link Status                               System:  SYSTEMA
Type options, press Enter
 5=Display Loop Details   6=Display Connections Details

Opt   Loop Number   Resource   HSL OptiConnect Status
5     256           SB01      Active
      257           SB02      Active
      259           SB03      Active

F3=Exit  F5=Refresh  F6=Display Optical Links  F12=Cancel

Bottom
```

Figure 16. Display OptiConnect Link Status, Part 1

**Note:** If your hardware configuration includes HSL OptiConnect, you can still access information relating to fiber-optic links by pressing the F6=Display Optical Links

function key on the *Display OptiConnect Link Status* screen.

The *Display Loop Details* screen shows the status of a specific High Speed Link ring. It provides information on the bus adapter/port on each side of a system connection. To access this screen, type option 5:

5=Display Loop Details

in the **Opt** field.

```

                                Display Loop Details
                                System:  SYSTEMA
Loop Number . . : 256

-----From-----
Resource Name  Port
BC02          C00
BC01          A00

-----To-----
Resource Name  Port
BC01          A01
BC02          C01

Hardware Status
Operational
Operational

                                Bottom

F3=Exit  F5=Refresh  F6=Display Connection Details  F12=Cancel

```

Figure 17. Display Loop Details

You can also obtain information on the status of an HSL OptiConnect connection from the issuing system to another system by accessing the *Display Connection Details* screen. To view this screen, press the

F6=Display Connection Details

function key.

```

                                Display Connection Details
                                System:  SYSTEMA
Local Loop . . . . . : 256

Resource/      Local      Remote      Remote      Connection
System         Resource   Resource    Loop         Status
BC02
SystemB       SOC01     SOC03      256          Varied on
SystemC       SOC02     SOC04      257          Active

                                Bottom

F3=Exit  F5=Refresh  F6=Display Loop Details  F12=Cancel

```

Figure 18. Display Connection Details

If your hardware configuration does not include HSL OptiConnect, the following screen will appear:

Display OptiConnect Link Status						
					System:	SYSTEMA
System Resource	-----Remote Optical Links-----			Remote Bus	Connection Status	
	Top Link	Bottom Link	Redundant Link			
SYSTEMB						
SOC13	Active	Ready	Ready	4	Active	
SOC02	Ready	Active	Ready	5	Active	
SYSTEMC						
SOC08	Active	Ready	Down	2	Active	
SOC10	Unknown	Unknown	Unknown		Failed	
SYSTEMD						
SOC07	Active	Ready	Ready	6	Active	
SOC04	Ready	Active	Ready	7	Active	
					Bottom	
F3=Exit F5=Refresh data F11=Display local links F12=Cancel						

Figure 19. Display OptiConnect Link Status

This Display OptiConnect Link Status screen above shows information related to remote optical links. Information can also be obtained on local optical links. To access this screen, press the:

F11=Display Local Links

function key.

Display OptiConnect Link Status						
					System:	SYSTEMA
System Resource	-----Local Optical Links-----			Remote Bus	Connection Status	
	Top Link	Bottom Link	Redundant Link			
SYSTEMB						
SOC13	Active	Ready	Ready	6	Active	
SOC02	Ready	Active	Ready	7	Active	
SYSTEMC						
SOC08	Active	Ready	Down	6	Active	
SOC10	Unknown	Unknown	Unknown		Failed	
SYSTEMD						
SOC07	Active	Ready	Ready	6	Active	
SOC04	Ready	Active	Ready	7	Active	
					Bottom	
F3=Exit F5=Refresh data F11=Display bus owner F12=Cancel						

Figure 20. Display OptiConnect Link Status

Information can also be obtained to indicate the bus owner. To access this Display OptiConnect Link Status, press the

F11=Display bus owner

function key.

Display OptiConnect Link Status						System: SYSTEMA
System Resource	Local Bus	Remote Resource	Remote Bus	Bus Owner	System Card	
SYSTEMB						
SOC13	6	SOC10	4	SYSTEMA	2	
SOC02	7	SOC04	5	SYSTEMD	2	
SYSTEMC						
SOC08	6	SOC24	2	SYSTEMA	3	
SOC10				SYSTEMD		
SYSTEMD						
SOC07	6	SOC12	6	SYSTEMA	1	
SOC04	7	SOC06	7	SYSTEMD	0	

Bottom

F3=Exit    F5=Refresh data    F11=Display Remote Links    F12=Cancel

Figure 21. Display OptiConnect Link Status

The Display OptiConnect Link Status screens show the following:

- The local system/resource and the associated local bus number
- Remote resource
- Remote bus number
- Bus owner: the system that owns the shared bus
- Link status
  - Active: Cable in use for logical path SOCxx
  - Ready: Cable available for use
  - Down: Failure in cable, or optical hardware or remote system is down
  - Unknown: Remote system could not be contacted
- Connection status
  - Vary on pending: Remote system could not be contacted
  - Varied on: Normal status
  - Varyon/degraded: Normal status; redundancy lost
  - Active: Normal status; currently in use
  - Active/degraded: Same as *Active* with redundancy lost
  - Failed: Failed

You may receive a connection status message indicating some troubleshooting is required. Review the following to help with potential problems:

- Any status for a Link or Connection of *Active*, *Ready*, or *Varied on* indicates that OptiConnect is operating correctly.
- If a system shows a Link Status of *Down*, then either a hub system is down or a cable/OptiConnect card has failed. The same is true for a Connection Status of *Varyon/degraded*, or *Active/degraded*. To solve this problem:
  1. Check that all systems are operational
  2. If a hub system is down, wait for it to be powered up and try the command again
  3. If all hubs are operational, call your IBM Service Representative

**Note:** This does not apply to customers with 500 or 510 systems in an OptiConnect cluster.

- If a link status is *Unknown* or Connection Status is *Vary on pending*, check that the remote system is operational, and that the QSOC subsystem has been started.
- If the DSPOPCLNK screen is blank, then QSOC subsystem has not started on the system that you are signed on.

To print the entire Display OptiConnect Link Status screen use the Display OptiConnect Link Status DSPOPCLNK OUTPUT(\*PRINT) command.

## Determining Hardware Resources

The Work with Hardware Resources (WRKHDWRSC) command is used to display information on OptiConnect adapters. The adapters represent systems that are linked to this system through the shared bus or HSL environment. An adapter that is associated with this system is **NOT** shown.

### Work with Hardware Resources

To display the OptiConnect adapters, use the Work with Hardware Resources command. Enter the following:

```
WRKHDWRSC TYPE(*CSA)
```

WRKHDWRSC TYPE(\*CSA) displays a resource for each remote system that had, at some point, an operational connection to the system on which you are entering the command.

The examples in the following sections demonstrate a four-system, dual-path configuration that shows SYSTEMA as the bus-owning system (Hub).

Work with Coupled Resources

System: SYSTEMA

Type options, press Enter.  
7=Display resource detail

Opt	Resource	Type-Model	Status	System	Text
	LB06		Operational		Host Bus
7	SOC13	2685-000	Operational	SYSTEMB	Shared Bus Adapter
	SOC08	2683-000	Operational	SYSTEMC	Shared Bus Adap
	SOC07	2685-000	Operational	SYSTEMD	Shared Bus Adap
	LB07		Operational		Nonhost Bus
	SOC04	2682-000	Operational	SYSTEMD	Bus Adapter
	SOC02	2685-000	Operational	SYSTEMB	Shared Bus Adap
	SOC10	2683-000	Inoperative	SYSTEMC	Shared Bus Adap

Bottom

F3=Exit   F5=Refresh   F6=Print   F12=Cancel

Figure 22. Work with Coupled Resources

Communication between two systems uses a pair of adapters: a source adapter, and a target adapter. The source adapter is the adapter to which a system is connected with optical cables. The target adapters are any remaining adapters on the shared bus that are connected to other systems. The WRKHDWRSC command does **not** display the source adapters to which you are optically connected. It displays the target adapters for *other* system adapters on the shared bus. These, in turn, represent systems to which you can communicate.

**Note:** Virtual SPD adapters might also display on the *Work with Coupled Resources* screen. They will have an adapter type of 268B and a text description of Virtual Bus Adapter. HSL adapters will have an adapter type of 268A and a text description of Nonhost Bus.

Some resources may have a status that is “Not detected”. This is caused by:

- A change in your configuration.
- A remote system that was not powered up when the OptiConnect system was started.

If a remote system was not powered up when the OptiConnect system was started, then power on the system. The resource should become operational as soon as the IPL on that system completes. The connection will still be displayed even though the subsystem on the remote system is not operational.

Next, select option 7 to display resource details such as physical location and logical address. Fields are blank for cards that physically reside in a bus on another system. Serial numbers appear as zeros for these cards.

```

                                Display Resource Detail
                                System:  SYSTEMA
Resource name . . . . . : SOC13
Text . . . . . : Shared Bus Adapter
Type-Model . . . . . : 2685-000
Serial Number . . . . . : 00-00000
Part Number . . . . . :

Physical location:
Frame ID
Card position
Logical address:
SPD bus:
System bus                6
System board              0
System card               1

                                Bottom

Press Enter to continue.

F3=Exit  F5=Refresh  F6=Print  F12=Cancel

```

Figure 23. Displaying Resource Details

### Displaying Hardware Resources

Use the Display Hardware Resource (DSPHDWRSC) command to display, print, or direct to an output file, OptiConnect adapter information. This information consists of resource name, status, location, resource description, and the remote systems that are connected to the OptiConnect adapters. The following example prints the information:

```
DSPHDWRSC TYPE(*CSA) OUTPUT(*PRINT)
```

You see the same type of information that is shown in Figure 22 on page 35 and Figure 23.

---

## Chapter 5. Setting up and Customizing OptiConnect

Any iSeries 400 application that was written to use Distributed Data Management (DDM) can use OptiConnect. This is true for existing applications as well as new applications. Many applications that use an iSeries 400 database can transparently use DDM without changes to the application. OptiConnect uses the same mechanism as traditional DDM, where the DDM file controls access to a database. Applications that access a database by using OptiConnect DDM can also use traditional APPC DDM to access another database at the same time.

There are two ways to route data requests through OptiConnect. The first is the **Fastpath OptiConnect** method and involves specifying a special keyword in the DDM file. The second method involves setting up **Extended Function Path OptiConnect**. If you are using the Fastpath method, OptiConnect agent jobs start in the OptiConnect Connection Manager and run in the QSOC subsystem. These jobs follow the OptiConnect job naming convention. Fastpath OptiConnect is the faster means of communication due to shorter code path, but two-phase commit protocols are not supported.

If the Extended Function Path method is used, OptiConnect agent jobs are started by the advanced program-to-program communications (APPC) attach manager and run in QCMN subsystem. The agent job names follow the standard DDM naming conventions for communication jobs. Two-phase commit protocols are supported.

---

### Utilizing OptiConnect

Fastpath OptiConnect utilizes a special device description of QYCTSOC. When an APPC conversation is directed at this device, the OptiConnect device driver redirects the conversation through the OptiConnect bus. This will bypass most of the standard DDM, DRDA<sup>®</sup>, and APPC code.

**Note:** The QYCTSOC device description will be created during the software installation, but will always remain varied off. This device description is necessary and should not be deleted.

The second method for setting up OptiConnect is to configure an APPC device and controller. The controller description will have a type of \*OPC, indicating to the device driver layer to use the bus. However, you cannot bypass some of the communication layers, as with the Fastpath method. This method is necessary for certain functions like two-phase commit, and some Lotus<sup>®</sup> Domino<sup>™</sup> Apps (LS:DO) that use LS:DO to access remote data. This is known as Extended Function Path OptiConnect.

---

### Setting up Fastpath OptiConnect Routing

To route data requests over OptiConnect by using the Fastpath method, you need to specify the **QYCTSOC** keyword in the device description parameter of the DDM file. You can use either the Create Distributed Data Management File (CRTDDMF) command, or the Change Distributed Data Management File (CHGDDMF) command to add this information.

When you create a new DDM file, do the following:

- For the Remote Location parameter, specify the system name of the target system where the request will be performed. (Display Network Attributes (DSPNETA) for the system name)
- When you have entered the rest of the information, press F10 (Additional parameters), page down (F8), and enter QYCTSOC for the device description. OptiConnect does not specifically use the other parameters on the CRTDDMF command. However, make sure that you have specified a valid selection (either \*NO or \*YES) for the Share Open Data Path parameter.

**Note:** When you specify QYCTSOC for the device, the remote location parameter is limited to a valid AS/400 system name.

When you change an existing DDM file, do the following:

- Enter the name of the DDM file and the library. Press Enter.
- For the Remote Location parameter, specify the name of the target system where the request will be performed. Press F10 (Additional parameters).
- On the Additional Parameters display, page down (F8), and enter QYCTSOC for the device description.

OptiConnect does not specifically use the other parameters on the CHGDDMF command. However, make sure that you have specified a valid selection for the Share Open Data Path parameter.

```

                                Create DDM File (CRTDDMF)

Type choices, press Enter.

DDM file . . . . . > TEST           Name
Library . . . . . > QGPL           Name, *CURLIB
Remote file:
File . . . . . > TEST             Name, *NONSTD
Library . . . . . > QGPL           Name, *LIBL, *CURLIB
Nonstandard file 'name' . . .

Remote location . . . . . > SYSTEMA   Name
Text 'description' . . . . . *BLANK

More..
F3=Exit  F4=Prompt  F5=Refresh  F12=Cancel  F13=How to use this display
F24=More keys

```

Figure 24. Creating a DDM file to use OptiConnect (View 1)

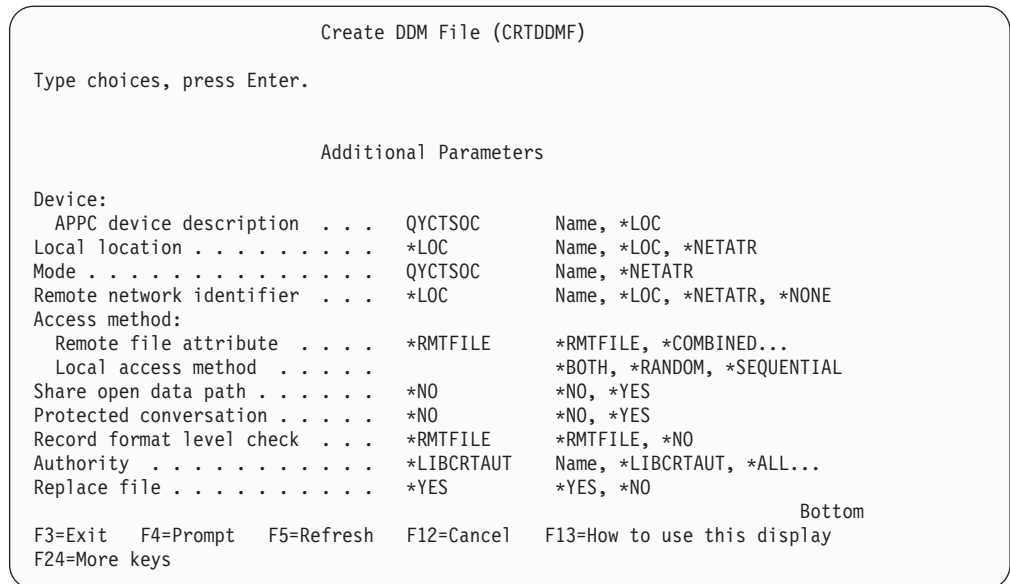

Figure 25. Creating a DDM file to use OptiConnect (View 2)

OptiConnect, by default, will accept any value in the **mode** parameter of a DDM file. However, if you want OptiConnect Agent jobs to start with the USRPRF specified in the QYYCDTSU job description, then you must use QYCTSOC in the mode parameter. Any other value in the mode parameter will result in the OptiConnect Agent job starting with the USRPRF, and the job description that initiated the DDM conversation. For more information, see “Use of Mode Tables” on page 52.

## Setting up Extended Function Path Routing

To route data requests through OptiConnect without using the special device keyword, you create OptiConnect controllers and devices of type \*OPC. The \*OPC controller needs to be link type of \*OPC. The remote system name must be the name of the target system.

Use the following commands to configure the \*OPC controller:

1. Create the controller description.

```

CRTCTLAPPC CTLD(name) LINKTYPE(*OPC) RMTSYSNAME(sysname)
ROLE(*PRI or *SEC) DSAP(##)

```

You must create a pair of \*OPC controllers (one on each of the two systems that uses OptiConnect to communicate). The Data Link Role of one system must be \*PRI (primary), and the other must be \*SEC (secondary). Setting the destination service access point (DSAP) value will set both the source service access point (SSAP), and DSAP parameters. The DSAP value must be valid and identical for both controllers on both systems in the pair. Valid values are 04, 08, 0C, 10, 14, ...78, 7C.

The following is an example of creating an \*OPC controller on two systems: SYSTEMA and SYSTEMB. To create a controller on SYSTEMA to connect to SYSTEMB, enter the Create Controller Description (CRTCTLAPPC) command.

```

                                Create Ctl Desc (APPC) (CRTCTLAPPC)

Type choices, press Enter.

Controller description . . . . . > SYSBCTL           Name
Link type . . . . . > *OPC                         *ANYNW, *FAX, *FR, *IDLC...
Remote System Name . . . . . > SYSTEMB             Character value
Data link role . . . . . > *PRI                     *NEG, *PRI, *SEC
LAN DSAP . . . . . > 44                            04, 08, 0C, 10, 14, 18, 1C...
Text 'description' . . . . . > *BLANK

                                                                Bottom
F3=Exit   F4=Prompt   F5=Refresh   F10=Additional parameters   F12=Cancel
F13=How to use this display   F24=More keys

```

Figure 26. Create Controller Description on SYSTEMA to connect to SYSTEMB

The joblog now shows:

```

> CRTCTLAPPC CTLD(SYSBCTL) LINKTYPE(*OPC) RMTSYSNAME(SYSTEMB)
      ROLE(*PRI) DSAP(44)
      Description for controller SYSBCTL created.

```

2. Create a device description for each controller on each system.

```

CRTDEVAPPC DEVD(SYSBDEV) RMTLOCNAME(SYSB) ONLINE(*NO) LCLLOCNAME(SYSA)
CTL(SYSBCTL) APPN(*NO)

```

The \*OPC controller will only accept devices that are created with APPN(\*NO). The RMTLOCNAME and LCLLOCNAME need to be mirror images of the RMTLOCNAME and LCLLOCNAME on the other system in the 'pair.' Parameter ONLINE at IPL should be \*NO since you cannot vary on OptiConnect controllers and attached devices until the QSOC subsystem has started.

The following are examples for creating an \*OPC device description to attach to the controller. To create a device description on SYSTEMA to attach to controller SYSBCTL, enter the Create Device Description (CRTDEVAPPC) command.

```

Create Device Desc (APPC) (CRTDEVAPPC)

Type choices, press Enter.

Device description . . . . . > SYSBDEV      Name
Remote location . . . . . > SYSB          Name
Online at IPL . . . . . > *NO            *YES, *NO
Local location . . . . . > SYSA          Name, *NETATR
Remote network identifier . . . . . > *NETATR  Name, *NETATR, *NONE
Attached controller . . . . . > SYSBCTL    Name
Mode . . . . . > *NETATR                Name, *NETATR
                                     + for more values
Message queue . . . . . > QSYSOPR        Name, QSYSOPR
Library . . . . . > *LIBL                Name, *LIBL, *CURLIB
APPN-capable . . . . . > *NO            *YES, *NO
Single session:
  Single session capable . . . . . > *NO    *NO, *YES
  Number of conversations . . . . . >      1-512
Location password . . . . . > *NONE
Secure location . . . . . > *YES         *NO, *YES, *VFYENCPWD
                                     More...
F3=Exit  F4=Prompt  F5=Refresh  F12=Cancel  F13=How to use this display
F24=More keys

```

Figure 27. Create Device Description on SYSTEMA to attach to controller description SYSBCTL

The joblog now shows:

```

> CRTDEVAPPC DEVD(SYSBDEV) RMTLOCNAME(SYSB) ONLINE(*NO)
  LCLLOCNAME(SYSA) CTL(SYSBCTL) APPN(*NO)
  Description for device SYSBDEV created.

```

3. On the other system in the 'pair,' create a controller and device description that will point to the previously created descriptions. On SYSTEMB enter the CRTCTLAPPC command to connect to SYSTEMA.

```

Create Ct1 Desc (APPC) (CRTCTLAPPC)

Type choices, press Enter.

Controller description . . . . . > SYSACTL    Name
Link type . . . . . > *OPC                *ANYNW, *FAX, *FR, *IDLC...
Remote System Name . . . . . > SYSTEMA      Character value
Data link role . . . . . > *SEC            *NEG, *PRI, *SEC
LAN DSAP . . . . . > 44                  04, 08, 0C, 10, 14, 18, 1C...
Text 'description' . . . . . > *BLANK

                                     Bottom
F3=Exit  F4=Prompt  F5=Refresh  F10=Additional parameters  F12=Cancel
F13=How to use this display  F24=More keys

```

Figure 28. Create Controller Description on SYSTEMB to connect to SYSTEMA

The joblog now shows:

```

> CRTCTLAPPC CTLD(SYSACTL) LINKTYPE(*OPC)
  RMTSYSNAME(SYSTEMA) ROLE(*SEC) DSAP(44)
  Description for controller SYSACTL created.

```

4. Create a device description on SYSTEMB to attach to controller SYSACTL. Enter the CRTDEVAPPC command.

```

                                Create Device Desc (APPC) (CRTDEVAPPC)

Type choices, press Enter.

Device description . . . . . > SYSADEV          Name
Remote location . . . . . > SYSA              Name
Online at IPL . . . . . > *NO                 *YES, *NO
Local location . . . . . > SYSB              Name, *NETATR
Remote network identifier . . . . . > *NETATR  Name, *NETATR, *NONE
Attached controller . . . . . > SYSACTL       Name
Mode . . . . . > *NETATR                     Name, *NETATR
                                + for more values
Message queue . . . . . > QSYSOPR           Name, QSYSOPR
Library . . . . . > *LIBL                   Name, *LIBL, *CURLIB
APPN-capable . . . . . > *NO                *YES, *NO
Single session:
  Single session capable . . . . . > *NO      *NO, *YES
  Number of conversations . . . . . >         1-512
Location password . . . . . > *NONE
Secure location . . . . . > *YES            *NO, *YES, *VFYENCPWD
                                                More...
F3=Exit  F4=Prompt  F5=Refresh  F12=Cancel  F13=How to use this display
F24=More keys

```

Figure 29. Create Device Description on SYSTEMB to attach to controller description SYSACTL

The joblog now shows:

```

> CRTDEVAPPC DEVD(SYSADEV) RMTLOCNAME(SYSA) ONLINE(*NO)
  LCLLOCNAME(SYSB) CTL(SYSACTL) APPN(*NO)
  Description for device SYSADEV created.

```

5. Repeat steps 1 and 2 for all the system pairs in the OptiConnect network.
6. Vary on all \*OPC controllers and devices to enable requests over OptiConnect.

When the first of a pair of \*OPC controllers is varied on, the status of the controller changes to ACTIVE/CNN PENDING or VARYON/CNN PENDING. That is, if the device is not varied on. This indicates that the OptiConnect path is not yet completely established. After the second of the \*OPC pair is varied on, both controllers change to ACTIVE status, and the OptiConnect connection is available for data transfer.

**Note:** You must start the QSOC subsystem on both systems prior to varying on the \*OPC controller and its associated devices. If the QSOC subsystem is ended on any system, the controllers on that system, and all connected systems, change to a status of ACTIVE/CNN PENDING or VARYON/CNN PENDING. After the QSOC subsystem has restarted, there cannot be any activity through these controllers until they are varied off, and then back on.

The following are examples to vary on controllers and devices. Use the VRYCFG command on SYSTEMA to vary on controller SYSBCTL.

```

Vary Configuration (VRYCFG)

Type choices, press Enter.

Configuration object . . . . . > SYSBCTL      Name
+ for more values

Type . . . . . > *CTL      *NWS, *NWI, *LIN, *CTL, *DEV
Status . . . . . > *ON      *ON, *OFF
Range . . . . . > *NET      *NET, *OBJ
Reset . . . . . > *NO      *NO, *YES

                                                    Bottom
F3=Exit  F4=Prompt  F5=Refresh  F12=Cancel  F13=How to use this display
F24=More keys

```

Figure 30. Vary Configuration on SYSTEMA to vary on controller SYSBCTL

The joblog now shows:

```

> VRYCFG CFGOBJ(SYSBCTL) CFGTYPE(*CTL) STATUS(*ON)
  Vary on completed for controller SYSBCTL.
  Vary on completed for device SYSBDEV.

```

Use the VRYCFG command on SYSTEMB to vary on controller SYSACTL.

```

Vary Configuration (VRYCFG)

Type choices, press Enter.

Configuration object . . . . . > SYSACTL      Name
+ for more values

Type . . . . . > *CTL      *NWS, *NWI, *LIN, *CTL, *DEV
Status . . . . . > *ON      *ON, *OFF
Range . . . . . > *NET      *NET, *OBJ
Reset . . . . . > *NO      *NO, *YES

                                                    Bottom
F3=Exit  F4=Prompt  F5=Refresh  F12=Cancel  F13=How to use this display
F24=More keys

```

Figure 31. Vary Configuration on SYSTEMB to vary on controller SYSACTL

The joblog now shows:

```

> VRYCFG CFGOBJ(SYSACTL) CFGTYPE(*CTL) STATUS(*ON)
  Vary on completed for controller SYSACTL.
  Vary on completed for device SYSADEV.

```

7. Setup DDM files:

Use the same locations for the Remote and Local location parameters that were previously specified in the APPC device description. Use \*LOC for the device description parameter. Remote and Local Locations that are defined in the devices attached to the \*OPC controllers can also be used in Structured Query Language (SQL) relational database directories. For more information, see “SQL over OptiConnect” on page 50.

Although varying on the \*OPC controllers and devices enables traffic over OptiConnect, varying off these devices and controllers does not necessarily block that traffic. To make certain that OptiConnect activity is stopped, use the vary option of the WRKOPCACT command, or end the QSOC subsystem.

The \*OPC controllers can be used to provide APPC communication capability across the OptiConnect bus. An application program using the ICF file interface, the CPI communication call interface, or the CICS<sup>®</sup> file interface can communicate with an application running on a remote system using OptiConnect. It is not restricted to previous OptiConnect applications such as DDM and SQL.

The default QYCTSOC APPC device description has \*PUBLIC authority \*CHANGE so any user can use OptiConnect. To keep the public from using OptiConnect, issue the command Revoke Object Authority (RVKOBJAUT). Then, grant access to the \*DEVD for specific users with the Grant Object Authority (GRTOBJAUT) command.

**Note:** The APPC device description does not describe a device, but is used to control authority and access to the OptiConnect path.

---

## Customizing OptiConnect

This section discusses the following topics:

- Routing SNA distribution services (SNADS) over OptiConnect
- Initial Library List
- Changing QUSER Authority Access
- QYYCDTSU Job description
- QYYCMGR Job description
- OptiConnect performance factors

### Routing SNADS over OptiConnect

SNADS (SNA Distribution Services) communication can use the OptiConnect link to distribute data between systems through the fiber-optic cable. When configuring SNADS over OptiConnect, the system uses the \*APPC controller and device descriptions previously created in “Setting up Extended Function Path Routing” on page 39. You will need to configure a directory entry, a routing table entry, and distribution queue in the following way:

1. Add a directory entry:

```
ADDIRE USRID(xxx/*ANY) (xxx is the address of remote system)
      USRD(xxx) (xxx is the description)
      SYSNAME(xxx) (xxx is the name of the remote system)
```

Add a directory entry to point a user or several users (\*ANY) to the remote system.

2. Create a distribution queue:

```

ADDSTQ DSTQ(xxx)          (xxx is the name of the queue)
      RMTLOCNAME(xxx)     (same as specified in the APPC DEVD)
      DSTQTYPE(*SNADS)
      MODE(*NETATR)       (or specify a mode)
      RMTNETID(*NETATR)
      LCLLOCNAME(xxx)     (same as specified in the APPC DEVD)

```

The values in the distribution queue for the RMTLOCNAME and LCLLOCNAME allow SNADS to select the correct APPC device description that points to the target system.

3. Create a routing table:

```

ADDSTRTE SYSNAME(xxx)    (xxx is the name of the remote system)
      FAST(xxx)          (xxx is the name of the remote system)
      STATUS(xxx)        (xxx is the name of the remote system)
      DATAHIGH(xxx)     (xxx is the name of the remote system)
      DATALOW(xxx)      (xxx is the name of the remote system)

```

**Note:** Create a routing table that points to the distribution queue.

4. Verify that QSOC and QSNADS subsystem are active on both systems.

## Initial Library List

The library list of a SOC Agent will default to the system and user library list system values. This will be sufficient to run standard DDM functions like DDM files, DDM data areas, and DDM data queues. This is because these objects require users to library qualify the target object at creation time. Other functions do not require the object to be qualified, such as:

- Distributed Relational Database Architecture (DRDA)
- Lotus Domino scripts with LS:DO and @Commands
- DB2 Triggers

**Note:** Changing the system value of the user or system library list can also do this. See “QYYCDTSU Job Description” on page 46.

You can control the library list of the remote jobs by changing the SOCA`nnnnnn` job description, QYYCDTSU, to include the necessary libraries. For DRDA and Domino you can either add the necessary library into the initial library list, or library qualify your SQL/ODBC statements. For triggers, you must include the library in the initial library list.

**Note:** If the SOCA`nnnnnn` jobs were started, you need to ENDSBS QSOC, and restart it so the agent jobs will start with the new initial library list.

## Changing QUSER Access Authority

The OptiConnect Agent jobs runs under the **QUSER** user profile when using the Fastpath OptiConnect method, by default. You may want to change these agent jobs to a more appropriate user profile. This will give the OptiConnect Agent jobs the appropriate access authority to files you will be using on the database system. Enter:

```
CHGJOBQ QSOC/QYYCDTSU
```

Press F4 and then press F10.

For the User parameter, change the default value QUSER to an appropriate user profile name. Specifically, one that controls the agent job authority.

See the following sections for information on the OptiConnect Job descriptions.

## QYYCDTSU Job Description

Figure 32 shows the QYYCDTSU job description for the SOCAmmnnnn jobs.

```

                                Display Job Description
                                System:  SYSTEMA
Job description:  QYYCDTSU      Library:  QSOC

User profile . . . . . :    QUSER
CL syntax check . . . . . :  *NOCHK
Hold on job queue . . . . . :  *NO
End severity . . . . . :    30
Job date . . . . . :      *SYSVAL
Job switches . . . . . :    00000000
Inquiry message reply . . . . . :  *RQD
Job Priority (on job queue) . . . . . :  5
Job queue . . . . . :      QSOC
  Library . . . . . :      QSOC
Output priority (on output queue) . . . . . :  5
Printer device . . . . . :  *USRPRF
Output queue . . . . . :  *USRPRF
  Library . . . . . :

                                More...

Press Enter to continue.

F3=Exit  F12=Cancel

```

Figure 32. Display Job Description - QYYCDTSU Job (Part 1 of 3)

```

                                Display Job Description
                                System:  SYSTEMA
Job description:  QYYCDTSU      Library:  QSOC

Message logging:
  Level . . . . . :    4
  Severity . . . . . :  0
  Text . . . . . :    *NOLIST
Log CL program commands . . . . . :  *NO
Accounting code . . . . . :  *USRPRF
Print text . . . . . :    *SYSVAL

Routing data . . . . . :    QYYCDTSU

Request data . . . . . :    *NONE

Device recovery action . . . . . :  *SYSVAL

                                More...

Press Enter to continue.

F3=Exit  F12=Cancel

```

Figure 32. Display Job Description - QYYCDTSU Job (Part 2 of 3)

```

Display Job Description
System:  SYSTEMA

Job description:  QYYCDTSU      Library:  QSOC

Time slice end pool . . . . . : *SYSVAL
Job message queue maximum size . . . . . : *SYSVAL
Job message queue full action . . . . . : *SYSVAL
Allow multiple threads . . . . . : *NO
Text . . . . . : SOC Agent Job Description

Initial library list:
  *SYSVAL

Press Enter to continue.
F3=Exit  F12=Cancel

Bottom

```

Figure 32. Display Job Description - QYYCDTSU Job (Part 3 of 3)

## QYYCMGR Job Description

The Connection Manager job, SOCMGR, maintains the agent jobs through the request data in the job description, QYYCMGR. Figure 33 shows QYYCMGR job description for the SOCMGR job.

```

Display Job Description
System:  SYSTEMA

Job description:  QYYCMGR      Library:  QSOC

User Profile . . . . . : QSOC
CL syntax check . . . . . : *NOCHK
Hold on job queue . . . . . : *NO
End severity . . . . . : 30
Job date . . . . . : *SYSVAL
Job switches . . . . . : 00000000
Inquiry message reply . . . . . : *RQD
Job priority(on job queue) . . . . . : 3
Job queue . . . . . : QSOC
  Library . . . . . : QSOC
Output priority (on output queue) . . . . . : 5
Printer device . . . . . : *USRPRF
Output queue . . . . . : *USRPRF
  Library . . . . . :

Press Enter to continue.
F3=Exit  F12=Cancel

More...

```

Figure 33. Display Job Description - QYYCMGR (Part 1 of 3)

```

Display Job Description
System:  SYSTEMA
Job description:  QYYCMGR      Library:  QSOC

Message logging:
Level  . . . . . : 4
Severity . . . . . : 0
Text . . . . . : *NOLIST
Log CL program commands . . . . . : *NO
Accounting code . . . . . : *USRPRF
Print text . . . . . : *SYSVAL

Routing data . . . . . : QYYCMGR

Request date . . . . . : CALL PGM(QSOC/QYYCMGR)
PARM(0 0 0)

Device recovery action . . . . . : *SYSVAL

Press Enter to continue.
F3=Exit  F12=Cancel
More...

```

Figure 33. Display Job Description - QYYCMGR (Part 2 of 3)

```

Display Job Description
System:  SYSTEMA
Job description:  QYYCMGR      Library:  QSOC

Time slice end pool . . . . . : *SYSVAL
Job message queue maximum size . . . . . : *SYSVAL
Job message queue full action . . . . . : *SYSVAL
Allow multiple threads . . . . . : *NO
Text . . . . . : SOC Connection Manager Job
Description
Initial library list:
  *SYSVAL

Press Enter to continue.
F3=Exit  F12=Cancel
Bottom

```

Figure 33. Display Job Description - QYYCMGR (Part 3 of 3)

The job description in Figure 33 on page 47 shows routing data for QYYCMGR. This should be listed as one of the routing entries in the QSOC subsystem description. The request data (*CALL PGM(QSOC/QYYCMGR) PARM(0 0 0)*) is the actual program call that initiates OptiConnect. The parameters describe the pool of agents that are maintained on the application system and are passed to the OptiConnect Connection Manager. You can change these parameters to tune the system's performance. The first number is the initial number of agents in the system (0). The second number is the minimum number of agents that are allowed

in the pool (0). The third number is ignored (0). For more information, see “OptiConnect Performance Factors”.

## OptiConnect Performance Factors

Several factors can affect the performance of OptiConnect:

- Storage Pool

OptiConnect is initially installed to use the \*BASE storage pool. You should determine if this storage pool, and the amount of storage that is allocated in the pool, is appropriate for each system in the cluster. Specify at least 16 MB per application system on the database system for OptiConnect.

- Job Class and Priority

The OptiConnect agents run under the QYYCAGNT class in the QSOC library. The agent job class is shipped to run at priority 20; however, the job will automatically run at the same priority as its corresponding source job.

- SOCMGR Job Description, QYYCMGR

As part of the job description for the SOCMGR, the request data calls the QYYCMGR program in the QSOC library. The parameters that are passed to the program are:

- The first number is the initial number of agent jobs that are started in the agent job pool. This number includes both active and available agent jobs. Active agents connect to a source DDM user job. Available agents are those that are not currently connected to a user job, but are waiting to be used. As active jobs end, the connection manager submits jobs to maintain the number of jobs in the agent job pool. This parameter is similar to the prestart jobs parameter that is used when starting a subsystem. When the subsystem starts, jobs are available.
- The second is the minimum number of available agents that are maintained in the agent job pool. As available agents become active agents, the Connection Manager submits jobs to maintain the number of available agent jobs. This number should always be less than 50.
- The third parameter value is ignored. Enter 0.

The default parameters are (0 0 0).

You can adjust these values to prestart a predetermined number of agent jobs. When a work request comes in, it gets sent directly to an agent job that is already running or prestarted. The number of agents should be adjusted according to the requirements of individual installations.

To prestart agent jobs, change the defaults for QYYCMGR job description. To change these values,

1. Enter:  
CHGJOB QSOC/QYYCMGR
2. Press F4, then press F10

For the request data, change the default PARM value (0 0 0) to the desired values.

**Note:** Prestart agent jobs can only be used by applications whose DDM files have QYCTSOC as the device. If the \*OPC controller method is used, DDM prestart jobs must be configured.

---

## Advanced OptiConnect Customization

This section discusses the following topics:

- SQL over OptiConnect
- Remote Journal Function
- Use of Mode Tables
- Remote Job Submission

### SQL over OptiConnect

You can route Static and Dynamic Structured Query Language (SQL) over OptiConnect through the use of Distributed Relational Database Architecture (DRDA). This can be done using either the Fastpath OptiConnect method, or the Extended Function Path OptiConnect method. The Fastpath OptiConnect method is easier to begin using, but you cannot use commitment control, or Distributed Unit of Work (\*DUW) for the connect method. If commitment control or \*DUW is needed, you will need to route SQL over OptiConnect by using the Extended Function Path method.

OptiConnect supports the use of static Structured Query Language (SQL) with both Dynamic, and Extended Dynamic SQL. You can also route Extended Dynamic SQL statements over OptiConnect by using the QXDA set of API's. Please refer to the *Series Information Center* for a complete listing.

#### Routing SQL using the Fastpath OptiConnect Method

To route SQL requests over OptiConnect using the Fastpath OptiConnect method, you need to specify special keywords in the relational database (RDB) directory. The database system must have an RDB entry that matches the relational database name specified on the application systems with \*LOCAL for the remote location parameter. On the application systems, the remote location parameter must point to the system where the database resides. Each relational database name must be unique within the distributed network. Each entry identifies the method of accessing the relational database as well as other parameters.

To add an entry to the relational database directory:

1. Enter the Add Relational Database Directory Entry (ADDRDBDIRE) command
2. Press F4=Prompt
3. Press F9=Show all parameters

```

Add RDB Directory Entry (ADDRDBDIRE)          SYSTEMA
Relational database . . . . . xxx          (name of the database entry)
Remote location:
  Name or address . . . . . xxx          (database system name)
  Type . . . . . *SNA
Text . . . . . RDB entry for OptiConnect

Port number or service program . *DRDA
Device:
  APPC device description . . QYCTSOC (keyword to route across OptiConnect)
Local location . . . . . *LOC
Remote network identifier . . . *LOC
Mode . . . . . *NETATR
Transaction program . . . . . *DRDA

```

Figure 34. Add RDB Directory Entry

1. Enter a name for the *Relational database* parameter.  
The name on the application system **must** match the name on the database system.
2. Enter the *Remote location* parameter.  
On each application system, specify the name of the target system. On the database system, specify \*LOCAL.
3. Enter QYCTSOC for the *APPC device description*.
4. Enter \*LOC for *Local location*.

After creating the relational database directory entry, you will need to recompile the SQL program to point to the RDB entry. When recompiling specify:

1. Commitment Control \*NONE
2. RDB connect method \*RUW

**Note:** The relational database parameter has to match the relational database parameter in the RDB entry.

**Routing SQL using the Extended Function Path Method**

To route SQL requests over OptiConnect using the Extended Function Path method, you need to specify the Remote location and Local location in the relational database (RDB) directory. Ensure that these match the Extended Function Path descriptions (previously created in “Setting up Extended Function Path Routing” on page 39).

Recompiling the SQL program pulls the target system name from the RDB entry, creates an SQL package, and runs the program on the target system.

**Remote Journal Function**

Remote Journal function can be routed over OptiConnect through the relational database (RDB) directory entry. This identifies the remote location name and other

necessary information. Remote Journal function can use either the Fastpath OptiConnect method, or the Extended Function Path method. See the *Backup and Recovery* book for more information.

## Use of Mode Tables

Modes describe session characteristics between the local and remote locations. The use of modes over OptiConnect provides greater flexibility than standard mode support over APPC. Modes over OptiConnect are invoked through a **mode table**. The mode table, QMTABLE, is not shipped with OptiConnect and needs to be created if additional customization is required.

When subsystem QSOC is started, the QSOC library is checked to see if QMTABLE exists. If QMTABLE does exist, the parameters will be used to start any OptiConnect Agents. Otherwise, a default set of values are placed in storage.

To create the OptiConnect Mode table, type the following:

```
CALL QSOC/QYYCMUTL CREATE
```

This creates the DDS source file QSOCDDS, with member QSOCDDS, and a sample mode table QMSAMPLE in the QSOC library. The mode table QMTABLE can be created by copying this sample table, or by using the DDS source file. QMTABLE is a physical file and needs to reside in the QSOC library. You can use data file utility (DFU) to alter this table, adding one entry for each mode or location required.

For the Fastpath OptiConnect method, add the following entry:

WORK WITH DATA IN A FILE	Mode. . . . :	ENTRY
Format. . . . . :	File. . . . . :	QMTABLE
MODREC		
MODE: QYCSOC	RMTLOC: *ANY	
LCLLOC: *ANY	JOBQ: QYYCDTSU	
JOBDLIB: QSOC	JOBQ: QSOC	
JOBQLIB: QSOC	DFTUSER: *JOBQ	
RCLRSC: *RCLRSC	JOBPRIOR *DYNAMIC	
INIJOB: 0	MINJOB: 0	
USREXIT: *OBJAUT	USREXITLIB: *LIBL	
CONJRNL: *NONE	CONJRNL LIB: *LIBL	
ROUTING: QYYCDTSU	JOBSTDLY: 200	
JOBENDDLY: 0		

Figure 35. Work with data in a file

**Note:** The ROUTING (entry) must always be QYYCDTSU to use the OptiConnect agents that are supplied with QSOC. No entry is required in the mode table for ObjectConnect.

The mode table is searched each time an agent job is started (DDM target) for a match against the keyed values. There are three keyed fields in QMTABLE: **LCLLOC**, **RMTLOC**, and **MODE**. The following priority scheme determines which table entry will be used. The table is searched for the following:

1. Target system name extracted from network attributes (matched against LCLLOC)
2. Source system name that was sent to the target system (matched against RMTLOC)

3. Mode which was also sent to the target system (matched against the MODE field)

A specific value for the above three fields can be matched in the table or '\*ANY.' A specific value is always taken over '\*ANY,' regardless of the order of the entries in the table.

1. A specific LCLLOC match is taken over a specific RMTLOC or a specific MODE.
2. A specific RMTLOC match is taken over a specific MODE.

**Note:** The Fields column in the mode table is case sensitive and all entries need to be in **uppercase**. Table 4 shows the fields and associated descriptions.

Table 4. Fields in the Mode table

Field	Description
RMTLOC	Remote location (from the server point of view)
LCLLOC	Local location (from the server point of view)
MODE	Mode description from DDM file
JOBID	Job description for the Agent job
JOBDLIB	Library for Agent job description
JOBQ	OptiConnect agent job queue (*JOBID for value from job description)
JOBQLIB	Library for OptiConnect Agent job queue
DFTUSER 1, 2	Default user profile for OptiConnect agent job <ul style="list-style-type: none"> <li>• *NONE means run under same user profile as client job 1</li> <li>• *JOBID means use user profile from job description</li> </ul>
RCLRSC	*RCLRSC for disable reclaim resource (default) <ul style="list-style-type: none"> <li>• *DDMCONV for disable reclaim DDM conversation</li> <li>• *BOTH for disable reclaim resource and reclaim DDM conversation</li> <li>• *NONE to enable both reclaim resource and reclaim DDM conversation</li> </ul> <b>Note:</b> Disable means that OptiConnect conversations will not be reclaimed.
JOBPRIOR	*DYNAMIC for change agent job priority when client job priority is changed (default) <ul style="list-style-type: none"> <li>• *STATIC for change agent job priority when the agent job is started</li> <li>• *NONE for do not change agent job priority</li> </ul>
INIJOB 3	This is the minimum number of agent jobs that are maintained in the agent job pool. This number includes both active and available agent jobs.
MINJOB 3	This is the minimum number of available agents that are maintained in the agent job pool. As available agents become active agents, the connection manager submits jobs to maintain the number of available agent jobs.
USREXIT 4	Program name - name of exit program if present <ul style="list-style-type: none"> <li>• *OBJAUT for object authority checking only job priority is changed (default)</li> <li>• *REJECT to reject all connections agent job is started</li> <li>• *NETATR use DDM EXIT value from network attributes</li> </ul>
USREXITLIB	Library for user exit program
CONJRNLIB	Name of journal for connection journaling <ul style="list-style-type: none"> <li>• *NONE for none.</li> </ul>
CONJRNLIB	Library for connection journaling

Table 4. Fields in the Mode table (continued)

Field	Description
ROUTING	Routing Data for Job
JOBSTDLY	This value controls the rate at which prestart jobs are started in milliseconds
JOBENDDLY	Allows the OptiConnect connection manager to shutdown before all idle jobs have ended. This allows the customer to continue with other operations; for example, backups. The remaining idle agents will end at a rate of 1 per JOBENDDLY milliseconds.

1. The QSOC user profile must have \*CHANGE authority to the user profile with which the agent job is submitted. If this authority does not exist, the agent job will not submit, and the client job will hang for two minutes until it times out.
2. The DFTUSER field replaces the APPC attribute SECURELOC from standard DDM security. This provides greater flexibility than standard DDM as the required security can be set individually for each DDM file.
3. Prestart agents cannot be started, and minimum agents cannot be maintained, if DFTUSER is set to \*NONE.
4. The USREXIT field overrides the network attribute field DDMACC.

## Security Considerations using the OptiConnect Mode Table

### OptiConnect Security Change for V4R5 and higher

An enhancement has been made to V4R5 Opticonnect function to make access between Opticonnected systems using DDM/DRDA more secured. Opticonnect now uses the Opticonnect Mode Table to manage and control jobs in each of the Opticonnected systems. When upgrading to V4R5 or higher from a release prior to V4R5, the OptiConnect Connection Manager will automatically create the Opticonnect Mode Table if one does not exist.

Depending on how the existing modes in the mode table are set up, this may result in an error message CPF9162 with error code '8403' when Opticonnect is started after the upgrade. To override this new authority arrangement, you can execute the procedure that follows this explanation.

### New Changes

There are two types of security possible when using DDM/DRDA over OptiConnect. These are achieved by altering the OptiConnect mode table, QSOC/QMTABLE. Attached below are comparison tables that show changes in default values between pre-V4R5 and V4R5 and higher mode tables.

#### Pre-V4R5

1. DEFAULT PROFILE:

This type of security is achieved, with the QYCTSOC mode, by forcing all OptiConnect agent jobs into using a set user profile by setting the DFTUSER field in the mode table to \*JOBID for it to pick up the USERID specified in the QYYCDTSU job description in the QSOC library.

#### V4R5 and higher

The authority associated with this USERID will now be used of all objects accessed by this OptiConnect Agent. The QYCTSOC mode is configured to use

the QYYCDTSU job description as a default at OptiConnect installation and the job description is the only thing that has to be changed.

The descriptions that follow show the results of using STRDFU command to change individual records in the mode table.

```

WORK WITH DATA IN A FILE      Mode . . . . :  CHANGE
Format . . . . :  MODREC      File . . . . :  QMTABLE

MODE:      QYCTSOC              RMTLOC:      *ANY
LCLLOC:    *ANY                 JOBQ:        QSOC
JOBDLIB:   *LIBL                DFTUSER:     *JOBQ
JOBQLIB:   *LIBL                JOBPRIOR:    *DYNAMIC
RCLRSC:    *RCLRSC              MINJOB:
USREXIT:   *OBJAUT              USREXITLIB: *LIBL
CONJRNL:   *NONE                CONJRNLIB:  *LIBL
ROUTING:   QYYCDTSU            JOBSTDLY:    200
JOBENDDLY:

```

## 2. SAME PROFILE:

This type of security requires that the user has to have a profile on each of the Opticonnected system. Assuming a two Opticonnected systems, when a user starts an OptiConnect job to SYSTEM B, the OptiConnect Agent will be started with the USERID which initiated the conversation, trusting that the user has already signed on to SYSTEM A. The SOC Agent will now run with the authority that the user has on SYSTEM B. This is achieved by placing \*NONE into DFTUSER field in the mode table on SYSTEM B. Here is how any mode, other than QYCTSOC which was previously configured for "Default Profile" security, can be configured for "Same Profile" security with a single mode table record.

```

WORK WITH DATA IN A FILE      Mode . . . . :  CHANGE
Format . . . . :  MODREC      File . . . . :  QMTABLE

MODE:      *ANY                 RMTLOC:      *ANY
LCLLOC:    *ANY                 JOBQ:        *USRPRF
JOBDLIB:   *LIBL                JOBQ:        QSOC
JOBQLIB:   *LIBL                DFTUSER:     *NONE
RCLRSC:    *RCLRSC              JOBPRIOR:    *DYNAMIC
INIJOB:
USREXIT:   *OBJAUT              MINJOB:
CONJRNL:   *NONE                USREXITLIB: *LIBL
ROUTING:   QYYCDTSU            CONJRNLIB:  *LIBL
JOBENDDLY:      JOBSTDLY:    200

```

## V4R5 and higher

Here are the default values in the mode table after upgrading to V4R5. Note that the USREXIT field has been changed from \*OBJAUT to \*REJECT. This disables "Same Profile" security and causes the OptiConnect Connection Manager to reject any mode other than QYCTSOC with is configured with a different mode table record. This results in an error message CPF9162 with a hex code of '8403'X, with means that the OptiConnect connection manager has rejected the mode.

```

WORK WITH DATA IN A FILE      Mode . . . . :  CHANGE
Format . . . . :  MODREC      File . . . . :  QMTABLE

MODE:      *ANY                 RMTLOC:      *ANY
LCLLOC:    *ANY                 JOBQ:        *USRPRF
JOBDLIB:   *LIBL                JOBQ:        QSOC
JOBQLIB:   *LIBL                DFTUSER:     *NONE
RCLRSC:    *RCLRSC              JOBPRIOR:    *DYNAMIC
INIJOB:
MINJOB:

```

```

USREXIT: *REJECT          USREXITLIB: *LIBL
CONJRNL: *NONE           CONJRNLLIB: *LIBL
ROUTING: QYYCDTSU       JOBSTDLY:          200
JOBENDDLY:

```

## Bypassing the New Security Enhancement

To bypass this new security enhancement, follow the steps below:

1. Back up the existing mode table:
  - Type CRTSAVF FILE(QUSRSYS/QMTABLE)
  - Type SAVOBJ OBJ(QMTABLE) LIB(QSOC) DEV(\*SAVF) OBJTYPE(\*FILE) SAVF(QUSRSYS/QMTABLE)
2. Run QYYCFIXM to update the mode table:
  - Type CALL QSOC/QYYCFIXM

You will see the following:

```
CPF9898 *REJECT CHANGED TO *OBJAUT IN *ANY *ANY *ANY MODE
TABLE ENTRY.
```
3. If OptiConnect is active, type CALL QSOC/QYYCMUTL RELOAD. This will activate the changes.

## Troubleshooting Hints

1. If the following message is received, the new security enhancement has been disabled.
 

```
CPF9898 *OBJAUT CHANGED TO *REJECT IN *ANY *ANY *ANY MODE TABLE
ENTRY.
```

To activate it, call QSOC/QYYCFIXM.
2. If the following message is received, the existing mode table entries are not \*ANY \*ANY \*ANY.
 

```
CPF9898 'MODE TABLE NOT CHANGED
```
3. If the default mode table is damaged, delete it. Stop and restart the QSOC subsystem. The Opticonnect Manager will then create a new mode table.

## OptiConnect Mode Table Reload

The OptiConnect mode table can be changed and reloaded by the OptiConnect Connection Manager without ending and restarting the QSOC subsystem. You can do this by running the following command:

```
CALL QSOC/QYYCMUTL RELOAD
```

There are several restrictions to this:

- A default user of \*NONE cannot be changed to any other value. A default user of any other value cannot be changed to \*NONE.
- If a job prestarts or available agent counts are decreased, available jobs will not be ended. However, the job counts will come down as the jobs are used up by new DDM connections.
- If the new table has an incorrect entry that prevents jobs from starting, and INIJOB and MINJOB are both zero, then do the following:
  1. Fix the error in the table. Change the INIJOB value to a non-zero value and reload the table.
  2. Change the INIJOB back to zero and reload the table again (this will not work if DFTUSER = \*NONE as no prestart jobs can start).

**Note:** This will allow you to avoid ending QSOC and restarting it.

## Journaling OptiConnect Transactions

If journaling transactions across the OptiConnect link is required, the connection transactions can be journaled. The journal name comes from the *connection journal* field of the OptiConnect **mode table**. If the first character of the name is not '\*', then the journal is assumed to exist. Subsequently, all DDM connections made with remote systems are logged.

To log connection transactions, create a journal that is called OPCTRC. The connection journal entry is of type '00' (user defined), and is described as follows:

1. Source fully qualified job name
2. Source system name
3. Target fully qualified job name
4. Target system name
5. Mode description
6. Time stamp

The SOCA<sup>n</sup> job on the target system logs this information.

## Remote Job Submission

OptiConnect allows jobs to be submitted on the local system and started as a batch job on the target system transparently. These jobs must be created using the Submit Job (SBMJOB) or Submit Database Jobs (SBMDBJOB) command. This transparency is achieved by replacing QCMD routing entry in a subsystem description (SBSD) with an entry that will route the submitted job to the remote system. The following is an example of how to configure job submission:

1. Create a routing entry that calls QYYCROUT with two input parameters.

**Note:** Routing entries do not allow program parameters. You will need to create a program to call QYYCROUT and pass the parameters. It should look like the following CL program example 'ROUTE<sup>n</sup>PGM':

```
PGM
CALL PGM(QSOC/QYYCROUT) PARM(ddmfile libname)
ENDPGM
```

2. Add a routing entry to a subsystem description (SBSD) and specify 'ROUTE<sup>n</sup>PGM' as the 'Program to Call'.
3. Create or change a job description to specify the routing data that is to be the compare value for the routing entry just added.

**Note:** All jobs submitted with this job description will run on the remote system by the QYYCROUT program.

4. When the job is submitted, QYYCROUT is started. QYYCROUT then extracts information from the DDM file passed in. This DDM file is not used after this. The parameter for the DDM file should be:
  - Device = QYCTSOC
  - Mode = BATCHJOB
  - LCLLOCNAME = \*LOC
  - REMOTE SYSTEM = target system name
5. QYYCROUT creates a data queue and a DDM file in library QTEMP. It starts a SOCA<sup>n</sup> job and creates a data queue on the target system.

6. QYYCROUT then retrieves job attributes, cancel severity, and local data area (LDA). The job and local data area information get sent to the remote data queue on the target system. The target system runs a program to receive this information and changes the target job's attributes to match the source job.
7. QYYCROUT will extract information about inline data files and copy them to QTEMP in the target job.

The job queue on the source system receives request data one command at a time and runs each request on the target. After each command is run, the target job returns an indication of whether or not cancel severity has been exceeded. This allows QYYCROUT to decide if the job should be terminated. Since commands are run one at a time, holding the job on the source system will end command execution on the target system until released.

After all the requests have been received and run, and if message logging is set to something other than \*NOLIST, the target joblog is retrieved and written to QPJOBLOG. The user data field is set to the target system name.

To route the spooled file back to the source system:

1. Create a Remote Output queue by using the CRTOUTQ command.
2. Specify the system name that you will be routing files to in the Remote System parameter. This will allow you to supply information to the remaining parameters.
3. For the Remote Print Queue (RMTPRINTQ) parameter, specify the output queue to which the remote writer sends the spooled file.
4. Issue the Start Remote Writer (STRRMTWTR) command on the target system. See Figure 36 on page 59 and Figure 37 on page 60.

# Remote Job Submission Source System

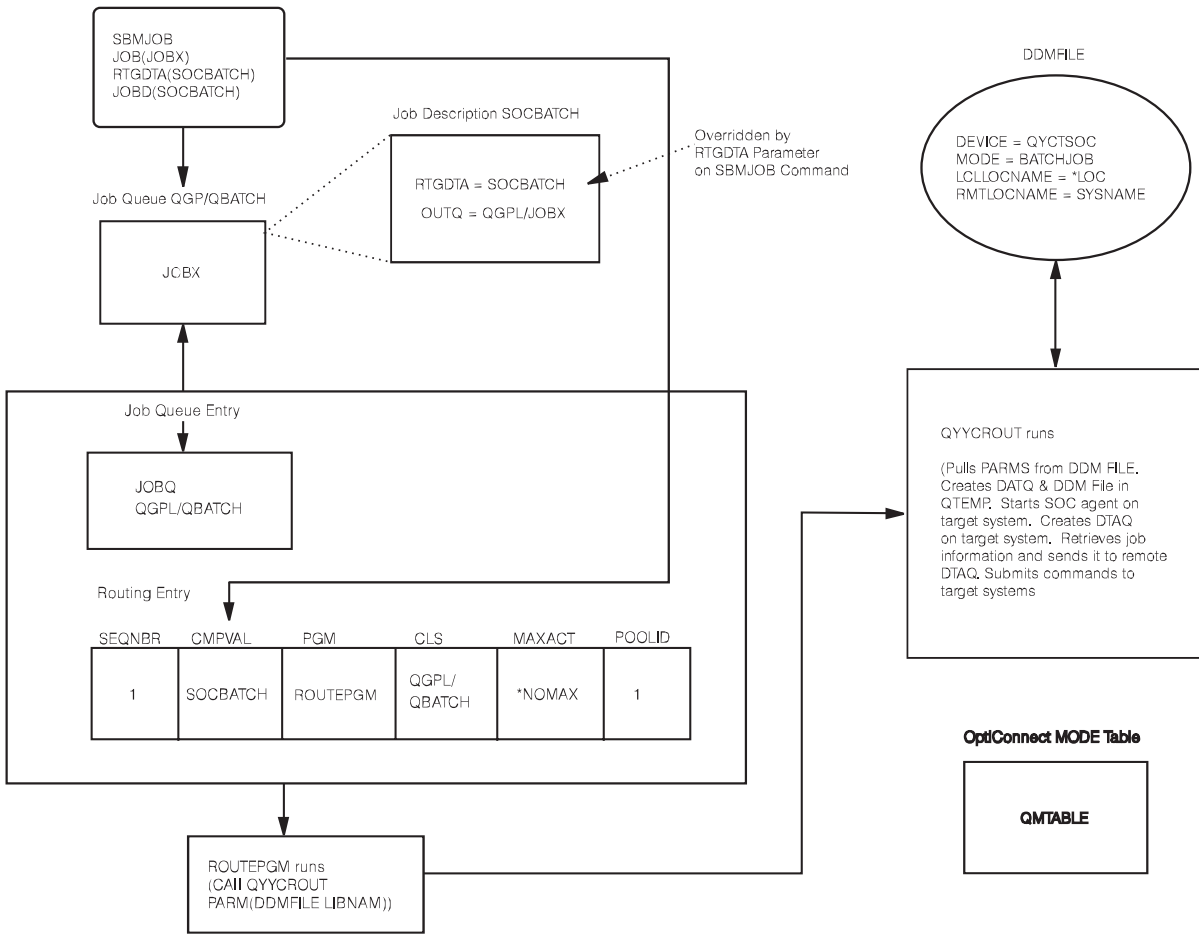

RV4F202-2

Figure 36. Remote Job Submission Source System

# Remote Job Submission Target System

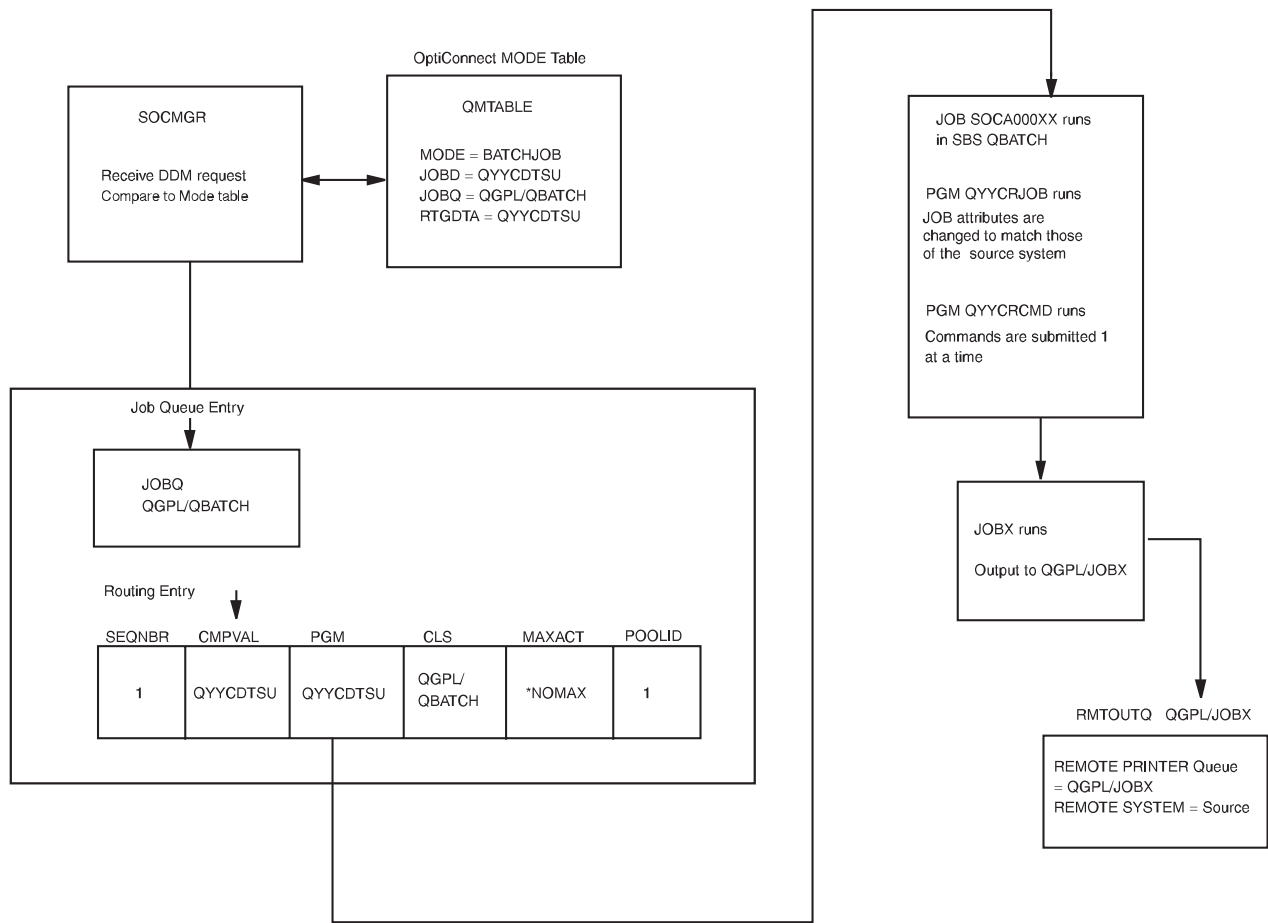

RV4F203-0

Figure 37. Remote Job Submission Target System

---

## Chapter 6. TCP/IP over OptiConnect

This function allows applications that utilize Transmission Control Protocol/Internet Protocol (TCP/IP) to communicate over OptiConnect. This can be accomplished when running in an AS/400 cluster with the OptiConnect shared bus, HSL, or logical partitioning environment. Applications that are distributed across multiple AS/400s, can take advantage of the high bandwidth and low latency of OptiConnect.

---

### Features

The functions main purpose is to provide a standard IP interface. This allows existing applications and services to work unchanged by simply defining a TCP/IP interface that uses OptiConnect. After an interface is configured and started, normal IP routing will be used to send packets over OptiConnect.

TCP/IP over OptiConnect:

- Allows the configuration of TCP/IP interfaces across the OptiConnect link using standard methods (Configure TCP/IP (CFGTCP) or Operations Navigator).

**Note:** Up to eight IP interfaces, each one on a separate subnet, can be configured to OptiConnect.

- Operates with standard functions (start, end, display).
- Allows support of IP packets. That is, all protocols that use Internet Protocol (IP), including Transmission Control Protocol (TCP), User Datagram Protocol (UDP), and so forth.
- Allows direct communication to other systems on the shared bus, or buses, which have configured an IP interface with the same subnet.
- Supports broadcast and multicast.

### Defining the OptiConnect Interface

Use the Add TCP/IP Interface (ADDTCPIFC) command to define a new interface to the Transmission Control Protocol/Internet Protocol (TCP/IP) configuration. The interfaces defined by the ADDTCPIFC command are logical interfaces.

#### Required parameters

- **INTNETADR:** Specifies an internet address that the local system responds to on this interface. An interface associates with a line description. The internet address is specified in the form `nnn.nnn.nnn.nnn`, where `nnn` is a decimal number ranging from 0 through 255. An internet address is not valid if it has all binary ones, or all zeros for the network identifier (ID) portion of the address. If you enter the internet address from a command line, enclose the address in apostrophes.
- **LIND:** The commands Add TCP/IP Interface (ADDTCPIFC) and Change TCP/IP Interface (CHGTCPIFC) have changed to allow a new special value of `*OPC` for the Line Description (LIND) parameter. This special value will be used to connect this TCP/IP interface with the OptiConnect transport layer.
- **SUBNETMASK:** Specifies the subnet mask, which is a bit mask that defines which portion of the internet address is treated as the (sub)network address and which portion is treated as a host address, on the given subnet.

### Optional parameter

- **LCLIFC:** The local IP interface is an optional parameter with which the internet address, previously defined in INTNETADR, will be associated. Defining an interface with an associated local IP address means that the associated local IP address will be used as the source IP address in packets originating from the interface. If no associated local IP address is specified, the source IP address on outbound packets will merely be the INTNETADR IP address of the interface. Any local LAN (token ring, ethernet, or FDDI) or \*VIRTUALIP interface may be used for LCLIFC.
  - \*NONE: no associated local interface used.
  - *local-interface*: Specify an associated local interface for the interface to be added.

**Note:** The specified associated local interface must already exist.

### Using the TCP/IP interfaces for OptiConnect

You can configure the TCP/IP interfaces for OptiConnect in either of two ways. In the first configuration, the OptiConnect bus is viewed similar to a LAN, and has a single subnet address. Each \*OPC interface is assigned a unique IP address within the subnet, thus defining the host's connection to that subnet. An example of this configuration is:

```
System A:
ADDTCPIFC INTNETADR('10.1.1.1') LIND(*OPC) SUBNETMASK('255.255.255.0')
System B:
ADDTCPIFC INTNETADR('10.1.1.2') LIND(*OPC) SUBNETMASK('255.255.255.0')
System C:
ADDTCPIFC INTNETADR('10.1.1.3') LIND(*OPC) SUBNETMASK('255.255.255.0')
```

In the second configuration, you can use the associated local interface parameter (*local-interface*). Using this method, you can configure the OptiConnect interfaces as part of existing local subnets to which the AS/400 is attached via other local interfaces (for example, token ring or ethernet interfaces). Each OptiConnect interface would define an endpoint of a point-to-point OptiConnect connection between two AS/400s. The existing local interface would then be specified as the associated local interface for the OptiConnect interface. An example of this configuration is:

```
System A:
ADDTCPIFC INTNETADR('9.1.1.1') LIND(TRNLIN) SUBNETMASK('255.255.255.0')
ADDTCPIFC INTNETADR('9.1.1.2') LIND(*OPC) SUBNETMASK('255.255.255.255') LCLIFC(9.1.1.1)
ADDTCPIFC INTNETADR('9.1.1.3') LIND(*OPC) SUBNETMASK('255.255.255.255') LCLIFC(9.1.1.1)
System B:
ADDTCPIFC INTNETADR('9.1.1.2') LIND(TRNLIN) SUBNETMASK('255.255.255.0')
ADDTCPIFC INTNETADR('9.1.1.1') LIND(*OPC) SUBNETMASK('255.255.255.255') LCLIFC(9.1.1.2)
ADDTCPIFC INTNETADR('9.1.1.3') LIND(*OPC) SUBNETMASK('255.255.255.255') LCLIFC(9.1.1.2)
System C:
ADDTCPIFC INTNETADR('9.1.1.3') LIND(TRNLIN) SUBNETMASK('255.255.255.0')
ADDTCPIFC INTNETADR('9.1.1.1') LIND(*OPC) SUBNETMASK('255.255.255.255') LCLIFC(9.1.1.3)
ADDTCPIFC INTNETADR('9.1.1.2') LIND(*OPC) SUBNETMASK('255.255.255.255') LCLIFC(9.1.1.3)
```

To use the associated local interface, you must configure an interface on each system, and both must be active. Using the example above, the following two lines represent a point-to-point configuration from System B to System C.

```
ADDTCPIFC INTNETADR('9.1.1.3') LIND(*OPC) SUBNETMASK('255.255.255.255') LCLIFC(9.1.1.2)
ADDTCPIFC INTNETADR('9.1.1.2') LIND(*OPC) SUBNETMASK('255.255.255.255') LCLIFC(9.1.1.3)
```

The advantage of the associated local interface technique is that there is no need to define new subnets for the OptiConnect bus. Subsequently, no external route tables need to be updated to provide connectivity between the OptiConnect interfaces and the rest of the TCP/IP network. Moreover, if one of the OptiConnect paths goes inactive, packets will automatically be routed over the backup interface. In

the case of the second example above, the TRNLINE. One disadvantage of this type of configuration is that an interface must be defined for every destination on the OptiConnect bus.

**Virtual OptiConnect:** OptiConnect for OS/400 software also supports virtual (inter-partition) OptiConnect. This is a high-speed internal link between partitions in a logical partitioning environment. Virtual OptiConnect allows logical partitions to communicate with each other without any hardware. It is another example of using the TCP/IP configurations shown above even if an OptiConnect bus does not exist. This environment can be configured as a collection of point-to-point links (shown in the previous example) or as an emulated LAN.

TCP/IP communication between the different partitions is achieved by a virtual OptiConnect bus. When one or more logical partitions do not have their own I/O ports and must connect to an external network via another partition, you can use \*VIRTUALIP interfaces as the associated local interfaces in a point-to-point configuration. TCP/IP routing code sees the path to another logical partition in the same manner as a physical OptiConnect bus. An example of a **point-to-point** configuration is:

```
Partition A:
ADDTCPIFC INTNETADR('9.1.1.1') LIND(TRNLINE) SUBNETMASK('255.255.255.0')
ADDTCPIFC INTNETADR('9.1.1.2') LIND(*OPC) SUBNETMASK('255.255.255.255') LCLIFC(9.1.1.1)
ADDTCPIFC INTNETADR('9.1.1.3') LIND(*OPC) SUBNETMASK('255.255.255.255') LCLIFC(9.1.1.1)
ADDTCPIFC INTNETADR('9.1.1.4') LIND(*OPC) SUBNETMASK('255.255.255.255') LCLIFC(9.1.1.1)

Partition B:
ADDTCPIFC INTNETADR('9.1.1.2') LIND(*VIRTUALIP) SUBNETMASK('255.255.255.255')
ADDTCPIFC INTNETADR('9.1.1.1') LIND(*OPC) SUBNETMASK('255.255.255.255') LCLIFC(9.1.1.2)
ADDTCPIFC INTNETADR('9.1.1.3') LIND(*OPC) SUBNETMASK('255.255.255.255') LCLIFC(9.1.1.2)
ADDTCPIFC INTNETADR('9.1.1.4') LIND(*OPC) SUBNETMASK('255.255.255.255') LCLIFC(9.1.1.2)

Partition C:
ADDTCPIFC INTNETADR('9.1.1.3') LIND(*VIRTUALIP) SUBNETMASK('255.255.255.255')
ADDTCPIFC INTNETADR('9.1.1.1') LIND(*OPC) SUBNETMASK('255.255.255.255') LCLIFC(9.1.1.3)
ADDTCPIFC INTNETADR('9.1.1.2') LIND(*OPC) SUBNETMASK('255.255.255.255') LCLIFC(9.1.1.3)
ADDTCPIFC INTNETADR('9.1.1.4') LIND(*OPC) SUBNETMASK('255.255.255.255') LCLIFC(9.1.1.3)

Partition D:
ADDTCPIFC INTNETADR('9.1.1.4') LIND(*VIRTUALIP) SUBNETMASK('255.255.255.255')
ADDTCPIFC INTNETADR('9.1.1.1') LIND(*OPC) SUBNETMASK('255.255.255.255') LCLIFC(9.1.1.4)
ADDTCPIFC INTNETADR('9.1.1.2') LIND(*OPC) SUBNETMASK('255.255.255.255') LCLIFC(9.1.1.4)
ADDTCPIFC INTNETADR('9.1.1.3') LIND(*OPC) SUBNETMASK('255.255.255.255') LCLIFC(9.1.1.4)
```

**Note:** This example assumes an earlier point-to-point configuration with \*VIRTUALIP mapped to a logical partition configuration.

An example of an **emulated LAN** environment is:

```
Partition A:
ADDTCPIFC INTNETADR('9.1.1.1') LIND(TRNLINE) SUBNETMASK('255.255.255.0') MTU(4096)
ADDTCPIFC INTNETADR('9.1.1.241') LIND(*OPC) SUBNETMASK('255.255.255.240') LCLIFC(9.1.1.1) MTU(4096)

Partition B:
ADDTCPIFC INTNETADR('9.1.1.242') LIND(*OPC) SUBNETMASK('255.255.255.240') MTU(4096)

Partition C:
ADDTCPIFC INTNETADR('9.1.1.243') LIND(*OPC) SUBNETMASK('255.255.255.240') MTU(4096)

Partition D:
ADDTCPIFC INTNETADR('9.1.1.244') LIND(*OPC) SUBNETMASK('255.255.255.240') MTU(4096)
```

For more information on this topic, see “Virtual OptiConnect” on page 4

**Proxy ARP with OptiConnect:** Proxy address resolution protocol (ARP) allows physically distinct networks to appear as if they are a single, logical network. This technique provides connectivity between these physically separate networks, without creating any new logical networks and without updating any route tables.

Proxy ARP allows systems that are not connected to the LAN to appear as if they are. When a system on the LAN wants to send data to one of the remote systems, it will do an ARP request to request the MAC (medium access control) address of the target system. When the AS/400 sees this request, it will reply to the request with the remote system's MAC address. Conversely, the system that requested the ARP will send its MAC address to the AS/400. The AS/400 will then forward the data to the remote system only if IP Forwarding is set to \*YES.

If you apply the above scenario in terms of OptiConnect, consider the following scenario:

- Two physically distinct networks: a LAN and one consisting of an OptiConnect bus need to communicate. In the above point-to-point configuration example, we assume that all systems are connected to the same OptiConnect bus and token-ring line. Suppose SYSTEM A has a token-ring connection and all access to SYSTEMB and SYSTEMC has to go through it. Proxy ARP provides the necessary connectivity to these physically distinct networks.

### **Starting the OptiConnect IP Interface**

To begin using the OptiConnect over TCP/IP, use the **Start TCP/IP Interface (STRTCPIFC)** command. This command starts a Transmission Control Protocol/Internet Protocol (TCP/IP) interface. This command can be used to do the following:

- Start interfaces that have been specified with the AUTOSTART(\*NO) value on the Add TCP/IP Interface (ADDTCPIFC) and Change TCP/IP Interface (CHGTCPIFC) commands.
- Start an interface that was previously ended by the End TCP/IP Interface (ENDTCPIFC) command.

### **Ending the OptiConnect IP Interface**

The **End TCP/IP Interface (ENDTCPIFC)** command is used to end a Transmission Control Protocol/Internet Protocol (TCP/IP) interface. When an interface is ended with this command, datagrams addressed to the IP addresses that are associated with this interface will no longer be accepted.

This command can be used to end an interface that was previously started by the Start TCP/IP Interface (STRTCPIFC), or Start TCP/IP (STRTCP) command.

#### **Notes:**

1. Regular and associated interfaces can be started and ended independently from starting and ending OptiConnect (when OptiConnect has ended, the interface is inoperative).
2. Once the interface has been started using the STRTCPIFC command, the status will show 'Active' if OptiConnect is up, but only 'Starting' if OptiConnect is down.
3. If the interface was active at one point, and the OptiConnect subsystem has ended, the status will show 'RCYPND' for recovery pending. Once OptiConnect is started, the interface should automatically go back to 'Active'.
4. For an associated interface, status will indicate 'Starting' even if OptiConnect is up. In order for the associated interface to be completely active, the other side must also be started with OptiConnect up.

For a detailed description of these and other TCP/IP commands, refer to the *TCP/IP Configuration and Reference* book.

---

## Chapter 7. OptiConnect Problem Determination

If you encounter problems when using OptiConnect, follow this procedure to find out why you are having difficulties. In general, it may be helpful to try the same DDM transaction over a communication link (LAN, for example). If no error occurs, follow the steps below to determine where OptiConnect is failing. If the error still occurs, the problem is not likely to be OptiConnect.

If all OptiConnect DDM accesses are failing, check the following:

1. Check to ensure that the system-to-system connections are operational by using the Work with Hardware Resources (WRKHDWRSC) command. Enter:

```
WRKHDWRSC TYPE(*CSA)
```

For more information on this command, see “Work with Hardware Resources” on page 35.

2. Check to ensure the cables are operational using:

```
DSPOPCLNK
```

3. Verify that QSOC subsystem is running on both the application systems and the database system by entering the following command on both:

```
WRKACTJOB SBS(QSOC)
```

4. Verify that the SOCMGR job is running in the QSOC subsystem. If the QSOC subsystem is not running, start it. If the subsystem is running, but there is no SOCMGR job, either the SOCMGR job has been ended, or a software failure has occurred. Locate the job log that is associated with the SOCMGR job by entering:

```
WRKJOB QSOC
```

Display the log to determine why the SOCMGR job ended. Report software failures by contacting your service provider.

5. Verify that the OptiConnect Connection Manager has established communications between the source and target systems. Each time a connection is opened or closed, a message is sent to the system operator message queue. Connections are closed when the QSOC subsystem has ended, the SOCMGR job has ended, a system is powered off, or a failure occurs. To display the system operator messages, enter:

```
DSPMSG MSGQ(*SYSOPR)
```

Otherwise, use the following command to select a particular time period:

```
DSPLLOG LOG(QHST)
```

**Note:** To see only QSOC messages, use DSPMSG QSOC.

6. Check to ensure that the QSOC job queue is not held. Enter:

```
WRKJOBQ JOBQ(QSOC/QSOC)
```

7. Verify that the correct remote location name, device, and mode are defined in the DDM file used for OptiConnect. See “Chapter 5. Setting up and Customizing OptiConnect” on page 37.

Follow these steps if you suspect a problem with a particular application:

1. Locate the failing job or job log on the source system.

2. Display the job log information and find this message:  
DDM JOB STARTED ON REMOTE SYSTEM
3. Use F1 to display the detailed message text. The detailed message text shows the OptiConnect agent job name.
4. Locate the agent job on the target system.
5. Inspect the job log information for both the application and agent jobs to locate any unexpected errors.
6. If MSGCPF9167 is encountered, see “Appendix A. Messages” on page 67 for more information on communications messages.

---

## Reestablishing System Connections when OptiConnect is Installed

You should always use the Power Down System (PWRDWNSYS) command when you power down a system that is connected with OptiConnect. If you do not use the PWRDWNSYS command, you could experience difficulties with system-to-system connections.

Certain conditions can cause system-to-system connections to become inoperative. Performing an IPL on one of the systems can only reestablish these connections.

You can avoid these conditions by using the PWRDWNSYS command. However, some conditions, such as abnormal operations, or loss of power on one system in the OptiConnect network, may make it necessary to perform an IPL. Additional examples are:

- Emergency power off (EPO)
- Utility or uninterruptible power supply failure
- Hardware failures
- Interrupted IPLs or failure of an IPL

If you suspect one of these conditions has occurred, check the status of the bus expansion adapter by using the Work with Hardware Resources (WRKHDWRSC) command. For more information on using this command, see “Work with Hardware Resources” on page 35. Report hardware failures by contacting your IBM Service Representative.

**Note:** Problems can occur if the odd bus on the Optical Link card was used to connect to a non-OptiConnect expansion unit. See “SPD OptiConnect Configurations” on page 12 for more information on OptiConnect configurations.

---

## Appendix A. Messages

OptiConnect provides messages that are kept in the QCPFMSG message file in QSYS library. You can display and print these messages by using the Work with Message File (WRKMSGF) command as follows:

```
WRKMSGF MSGF(QCPFMSG)
```

Or, you can use:

```
WRKMSGD CPDADA1
```

Detailed information can be displayed by selecting option 5 (Display details). You can also print from this display by using option 6 (Print).

When you are using OptiConnect, you may also see system messages that can be displayed as described above. These messages are also in the QCPFMSG message file in the QSYS library.

The list below describes the major/minor codes for message CPF9167. There are two pieces of information in the MSGCPF9167 secondary text. The first is the 'yyxx'X data. This information includes an error code followed by a function code. The second, which the message identifies as a major/minor return code, is a code point that identifies (to the OptiConnect developer) where the operation failed.

The MSGCPF9167 msg 'yyxx'X data in the second level text can be interpreted as follows:

- yy = Error Code (what failure was detected)
- xx = Function Code (what function was being run)

Error Codes:

- 01xx - Coupling Environment not open (for example, QSOC SBS and SOCMGR not up).
- 02xx - System name not found (results in CPF9162 - cannot establish DDM connection with remote system).
- 03xx - Source/Agent connection id invalid (for example, source or target job ended the OptiConnect conversation without a clean disconnect).
- 0403 - Source/target conversation startup error. This is typically due to timeout, but can happen due to other errors during startup.
- 05xx - Bad conversation state. Received the wrong message type when waiting for a request, response, or control message (for example, waiting for a request and received a control message or any other combination of request/response/control). Typically this happens when a "Close-Path" (conversation) is received due to unexpected error on the other job (look at target joblog if 05xx on source and vice versa).
- 06xx - Communication error - error from IPCF/transport layer. In a dual bus setup this typically means the operation could not be done on either adapter. Most operations will be automatically retried on the alternate connection if available. Errors returned from HMC I/O typically cause this error.
- 07xx - Transaction ended, this error is almost always 070B: Terminate waiting for response. Indicates an inflight request was ended without any response. This typically means the associated target (or source) job failed and ended

OptiConnect conversation without sending a response. However, this can also occur if communication between source and target systems was lost while a request was outstanding. The 06xx error occurs only if the communication is lost during request/response transport, while 07xx results because of failure during wait for response.

- 90xx - Internal Error. An unexpected or unhandled condition was detected by the OptiConnect device driver. A VLIC log with major or minor of 0700/0DDD is logged when this occurs. This may indicate a code problem or incorrect data (900B has been due to bad data in messages that are sent over the bus).

**Note:** There are also some known cases in the device driver where this error is due to loss of communication during certain states. That is, errors which should probably be 06xx sometimes show up as 90xx. A 90xx error, which happens at the same time as a SOCMGR OptiConnect connection closed message, is probably one which should have been 06xx.

Function Codes which may appear in MSGCPF9167:

- yy01 - Open-stream (connects job with OptiConnect device driver, should only fail if Coupling Environment not open = 0101)
- yy03 - Open-conversation (namely, Open-path; connects source and agent job through SOCMGR on the target system)
- yy05 - Close-conversation (namely, Close-path; disconnects source and agent job)
- yy07 - Send-request (send a request message; requests may be originated by either source or agent job)
- yy08 - Receive-request (receive a request message)
- yy0A - Send-response (send a response message; associated with a previous request message)
- yy0B - Receive-response

---

## Appendix B. OptiConnect Cluster Diagnostics

The following system bus and OptiConnect informational SRCs are the most common OptiConnect cluster related messages that are posted in the Product Activity Logs of systems in a cluster.

### **B600 699C Wrap Plug Installed on Bus**

This informational SRC indicates that a wrap plug is installed in a bus port on an Optical Link Processor card (f.c. 2688 or 2686).

### **B600 69A8 Link Operational**

This informational SRC indicates that a fiber-optic link has become operational again. The satellite system will post the message. This is normally seen after reconnecting the redundant link cable.

### **B600 69C1 Loss of Contact With the Remote System**

This informational SRC indicates that a remote system in an OptiConnect cluster has been brought down, or has crashed. To prevent this SRC during normal shutdown of a system in the cluster, run an ENDSBS QSOC \*IMMED before bringing the system down.

### **B600 69D8 Link Non-operational**

This informational SRC indicates that the fiber-optic link between two systems has become non-operational. Pulling a fiber-optic cable will result in this SRC. Since the OptiConnect hardware provides for redundant links, the hardware will switch over to the other fiber-optic link and continue to operate both buses on the one remaining cable.

During a Hub system power up, this SRC may occur during initial program load prior to completion and can be ignored.



---

## Notices

This information was developed for products and services offered in the U.S.A. IBM may not offer the products, services, or features discussed in this document in other countries. Consult your local IBM representative for information on the products and services currently available in your area. Any reference to an IBM product, program, or service is not intended to state or imply that only that IBM product, program, or service may be used. Any functionally equivalent product, program, or service that does not infringe any IBM intellectual property right may be used instead. However, it is the user's responsibility to evaluate and verify the operation of any non-IBM product, program, or service.

IBM may have patents or pending patent applications covering subject matter described in this document. The furnishing of this document does not give you any license to these patents. You can send license inquiries, in writing, to:

IBM Director of Licensing  
IBM Corporation  
500 Columbus Avenue  
Thornwood, NY 10594  
U.S.A.

For license inquiries regarding double-byte (DBCS) information, contact the IBM Intellectual Property Department in your country or send inquiries, in writing, to:

IBM World Trade Asia Corporation  
Licensing  
2-31 Roppongi 3-chome, Minato-ku  
Tokyo 106-0032, Japan

**The following paragraph does not apply to the United Kingdom or any other country where such provisions are inconsistent with local law:**

INTERNATIONAL BUSINESS MACHINES CORPORATION PROVIDES THIS PUBLICATION "AS IS" WITHOUT WARRANTY OF ANY KIND, EITHER EXPRESS OR IMPLIED, INCLUDING, BUT NOT LIMITED TO, THE IMPLIED WARRANTIES OF NON-INFRINGEMENT, MERCHANTABILITY OR FITNESS FOR A PARTICULAR PURPOSE. Some states do not allow disclaimer of express or implied warranties in certain transactions, therefore, this statement may not apply to you.

This information could include technical inaccuracies or typographical errors. Changes are periodically made to the information herein; these changes will be incorporated in new editions of the publication. IBM may make improvements and/or changes in the product(s) and/or the program(s) described in this publication at any time without notice.

Any references in this information to non-IBM Web sites are provided for convenience only and do not in any manner serve as an endorsement of those Web sites. The materials at those Web sites are not part of the materials for this IBM product and use of those Web sites is at your own risk.

Licensees of this program who wish to have information about it for the purpose of enabling: (i) the exchange of information between independently created

programs and other programs (including this one) and (ii) the mutual use of the information which has been exchanged, should contact:

IBM Corporation  
Software Interoperability Coordinator  
3605 Highway 52 N  
Rochester, MN 55901-7829  
U.S.A.

Such information may be available, subject to appropriate terms and conditions, including in some cases, payment of a fee.

The licensed program described in this information and all licensed material available for it are provided by IBM under terms of the IBM Customer Agreement, IBM International Program License Agreement, or any equivalent agreement between us.

Any performance data contained herein was determined in a controlled environment. Therefore, the results obtained in other operating environments may vary significantly. Some measurements may have been made on development-level systems and there is no guarantee that these measurements will be the same on generally available systems. Furthermore, some measurements may have been estimated through extrapolation. Actual results may vary. Users of this document should verify the applicable data for their specific environment.

Information concerning non-IBM products was obtained from the suppliers of those products, their published announcements or other publicly available sources. IBM has not tested those products and cannot confirm the accuracy of performance, compatibility or any other claims related to non-IBM products. Questions on the capabilities of non-IBM products should be addressed to the suppliers of those products.

All statements regarding IBM's future direction or intent are subject to change or withdrawal without notice, and represent goals and objectives only.

All IBM prices shown are IBM's suggested retail prices, are current and are subject to change without notice. Dealer prices may vary.

This information is for planning purposes only. The information herein is subject to change before the products described become available.

This information contains examples of data and reports used in daily business operations. To illustrate them as completely as possible, the examples include the names of individuals, companies, brands, and products. All of these names are fictitious and any similarity to the names and addresses used by an actual business enterprise is entirely coincidental.

#### COPYRIGHT LICENSE:

This information contains sample application programs in source language, which illustrate programming techniques on various operating platforms. You may copy, modify, and distribute these sample programs in any form without payment to IBM, for the purposes of developing, using, marketing or distributing application programs conforming to the application programming interface for the operating platform for which the sample programs are written. These examples have not been thoroughly tested under all conditions. IBM, therefore, cannot guarantee or imply reliability, serviceability, or function of these programs. You may copy,

modify, and distribute these sample programs in any form without payment to IBM for the purposes of developing, using, marketing, or distributing application programs conforming to IBM's application programming interfaces.

Each copy or any portion of these sample programs or any derivative work, must include a copyright notice as follows:

© (your company name) (year). Portions of this code are derived from IBM Corp. Sample Programs. © Copyright IBM Corp. \_enter the year or years\_. All rights reserved.

If you are viewing this information softcopy, the photographs and color illustrations may not appear.

---

## Programming Interface Information

This publication is intended to help you to setup and install OptiConnect for OS/400. This publication documents General-Use Programming Interface and Associated Guidance Information provided by OptiConnect for OS/400.

General-Use programming interfaces allow the customer to write programs that obtain the services of OptiConnect for OS/400.

---

## Trademarks

The following terms are trademarks of International Business Machines Corporation in the United States, other countries, or both:

Advanced 36  
Advanced 36 Information Directory  
Application System/400  
Advanced Peer-to-Peer Networking  
AFP  
AIX  
APPN  
C/400  
CallPath  
Client Access  
COBOL/400  
CICS  
CICS/400  
Customer Information Control System  
DB2  
DB2 Multisystem for AS/400  
DisplayWrite  
DRDA  
Distributed Relational Database Architecture  
GDDM  
Graphical Access for AS/400  
IBM  
IPDS  
iSeries  
iSeries 400  
Multiple Virtual Storage  
MVS  
ObjectConnect/400

Operating System/400  
OS/2  
OS/400  
OptiConnect  
OptiConnect/400  
OfficeVision/400  
PrintManager  
Print Services Facility  
RPG/400  
SOMobjects  
System/36  
System/38  
SystemView  
400

C-bus<sup>™</sup> is a trademark of Corollary, Inc. in the United States and/or other countries.

Java<sup>®</sup> and all Java-based trademarks and logos are trademarks or registered trademarks of Sun Microsystems, Inc. in the United States and/or other countries.

Microsoft<sup>®</sup>, Windows, Windows NT<sup>®</sup>, and the Windows logo are trademarks of Microsoft Corporation in the United States and/or other countries.

PC Direct<sup>™</sup> is a trademark of Ziff Communications Company in the United States and/or other countries and is used by IBM Corporation under license.

ActionMedia, LANDesk<sup>®</sup>, MMX<sup>™</sup>, Pentium<sup>®</sup>, and ProShare<sup>®</sup> are trademarks of Intel Corporation in the United States and/or other countries.

UNIX<sup>®</sup> is a registered trademark in the United States and/or other countries licensed exclusively through X/Open Company Limited.

SET<sup>™</sup> and the SET Logo are trademarks owned by SET Secure Electronic Transaction<sup>™</sup> LLC.

Other company, product, and service names may be the trademarks or service marks of others.

---

## Bibliography

The IBM publications listed here contain information about topics described or referred to in this guide. The following books are listed with their full title and base order number. When these books are referred to in text, the short title is used.

---

### iSeries 400

The following information can be helpful when you are installing and running OptiConnect.

- *Backup and Recovery*, SC41-5304-05, provides additional information needed to backup your system and on how to create backup copies of your system.
- *APPC Programming*, SC41-5443-00, describes the advanced program-to-program communications (APPC) support that is provided by the AS/400 system. It is intended for the application programmer responsible for developing application programs that use the APPC support. Included in this book are application program considerations, configuration requirements and commands, problem management for APPC, and general networking considerations.
- *Software Installation SNA Distribution Services*, SC41-5410-01, provides information about configuring a network using Systems Network Architecture Distribution Services (SNADS) and the Virtual Machine/Multiple Virtual Storage (VM/MVS) bridge. In addition, object distribution functions, document library services, system distribution directory services, and shadowing are discussed.
- *Software Installation*, SC41-5120-05, includes planning information and step-by-step instructions for the following procedures for installing the operating system and licensed programs. Topics include: initial installation, replacing the installed release with a new release, adding additional licensed programs, adding secondary languages, and changing the primary language of the system.
- *System Operation*, SC41-4203-00, provides information for the system operator responsible for maintaining the iSeries 400.
- *TCP/IP Configuration and Reference*, SC41-5420-03, provides information about configuring and using Transmission Control Protocol/Internet Protocol (TCP/IP) and writing programs to the TCP/IP application interface.
- *Work Management (SC41-5306-03)*, provides information about performance tuning, system values, collecting performance data, gathering system use data, using work entries, and scheduling batch jobs.



---

# Index

## Special Characters

- \*BASE storage pool 49
- \*CSA 35
- (WRKOPCACT, F14), Work with OptiConnect Jobs 27

## A

- access authority
  - changing QYYCDTSU 45
- accessing databases using OptiConnect 37
- active agents 49
- active jobs, listing 24
- activity of OptiConnect 24
- adapter
  - source adapter 35
  - target adapter 35
- Add RDB Directory Entry (ADDRDBDIRE) 50
- adding entry to Relational Database Directory 50
- adding QYCTSOC for device
  - description 37, 50
- adjusting for performance 49
  - agent jobs allowed in storage pool 49
  - job class 49
  - minimum number of agents in system 49
  - request data parameters 49
  - SOCMGR job control parameters 49
  - storage pool 49
- agent job 1
- agent job, SOCANnnnnn 19
- agent jobs 23, 49
- analyzing problems with OptiConnect 65
- APPC 3, 37
- APPC device description 39
- Appendix 69
- Application Programmer's Interface (API's) 1
- application system 18
- applications using OptiConnect 37
- authority 44
- autostart job 19
- autostart job entries 20
- available agents 49

## B

- B6xx XXXX 69
- batch job 57
- batch workload 18
- benefits of OptiConnect 2
- bibliography 75
- books, list of
  - communications equipment 75
  - iSeries 400 system 75
  - other iSeries 400 information 75
- bus 3

- bus capacity 25
- bus configuration 12
- bus receiver card 17
- Business Partner applications 8
- bytes read 25
- bytes written 25

## C

- cable 3
- cables 12
- card position 35
- Change DDM File (CHGDDMF) command 37
- changing entry to Relational Database Directory 50
- changing QUSER authority 44
- checking OptiConnect activity 24
- CHGDDMF command 37
- CHKPRDOPT 15
- CISC Cum 11
- CISC systems 3
- cluster 3
- collecting OptiConnect activity data 25
- command
  - WRKHWDWRSC 15
- commands
  - ADDRDBDIRE 50
  - Change DDM File (CHGDDMF) 37
  - CHGDDMF 37
  - CHKPRDOPT 15
  - Create Ctl Desc (APPC) (CRTCTLAPPC) 39
  - Create DDM File (CRTDDMF) 37
  - Create Device Desc (APPC) (CRTDEVAPPC) 39
  - CRTDDMF 37
  - Delete Licensed Program (DLTLICPGM) 11
  - Display Hardware Resources (DSPHDWRSC) 35, 36
  - Display OptiConnect Link Status (DSPOPCLNK) 19, 31
  - Display Subsystem Description (DSPSBSD) 20
  - DLTLICPGM command 11
  - DSPHDWRSC 35, 36
  - DSPOPCLNK 19
  - DSPSBSD 20
  - End Subsystem (ENDSBS) 23
  - ENDSBS 23
  - GRTOBJAUT 39
  - Power Down System (PWRDWNYSYS) 66
  - RCLDDMCNV 24
  - RCLRSC 24
  - Reclaim DDM Conversation (RCLDDMCNV) 24
  - Reclaim Resource (RCLRSC) 24
  - RVKOBJAUT 39
  - Save Licensed Program (SAVLICPGM) 11

- commands (*continued*)
  - SAVLICPGM 11
  - SBMDBJOB 57
  - SBMJOB 57
  - Start Subsystem (STRSBS) 23
  - STRRMTWTR 57
  - STRSBS 23
  - Vary Configuration (VRYCFG) 39
  - Verify OptiConnect Connection (VFYOPCCNN) 19
  - VFYOPCCNN 15, 19
  - Work with Active Jobs (WRKACTJOB) 24
  - Work with Hardware Resources (WRKHWDWRSC) 35
  - Work with Licensed Programs (WRKLICPGM) 11
  - Work with Message File (WRKMSGF) 67
  - Work with OptiConnect Activity (WRKOPCACT) 19, 25
  - WRKACTJOB 24
  - WRKHWDWRSC 35
  - WRKLICPGM 11
  - WRKMSGF 67
  - WRKOPCACT 15, 19, 25
- commitment control 50
- configurations
  - dual hub OptiConnect cluster 12
  - single hub OptiConnect cluster 12
- connection manager 1
- connection manager job, SOCMGR 19
- connection status 25, 31
- connections, system-to-system inoperative 66
- controlling access to a database 37
- coupled resources 35
- CPF9167 message 67
- CPU utilization 18
- Create Ctl Desc (APPC) (CRTCTLAPPC) 39
- Create DDM File (CRTDDMF) command 37
- Create Device Desc (APPC) (CRTDEVAPPC) 39
- creating new DDM file 37
- CRTCTLAPPC 39
- CRTDDMF command 37
- CRTDEVAPPC 39
- customizing OptiConnect 44

## D

- database system 18
- DB2 Multisystem for OS/400 8
- DDM 1, 3, 8, 18, 37
  - Standard OptiConnect routing 8
- DDM access failure 65
- DDM files 37
  - adding QYCTSOC for device 37
  - Change DDM File (CHGDDMF) 37
  - Create DDM File (CRTDDMF) 37

- DDM files 37 *(continued)*
  - mode parameter 37
  - remote location parameter 37
- DDS source file QSOCDDS
  - DFU 52
- degraded 17
- Delete Licensed Program (DLTLICPGM)
  - command 11
- description of message 67
- determining why you have problems 65
- device driver 1
- Device Driver 18
- Display Hardware Resources
  - (DSPHDWRSC) command 35, 36
- Display OptiConnect Link Status
  - (DSPOPCLNK) command 19, 31
- Display Station Passthrough 8
- Display Subsystem Description
  - (DSPSBSD) command 20
- displaying
  - locations 35
  - resource serial numbers 35
- displaying message description 67
- Distributed Data Management (DDM) 8
- Distributed Relational Database
  - Architecture (DRDA)
    - See DRDA 8
- Distributed unit of work (\*DUW) 50
- DLTLICPGM command 11
- DRDA 3
  - Structured Query Language (SQL) 8
- DSAP 39
- DSPHDWRSC 35, 36
- DSPOPCLNK 31
- DSPOPCLNK command 19
- DSPSBSD command 20
- dual hub configuration 12
- dynamic SQL 50

**E**

- EIA location 35
- emergency power off (EPO) 66
- enabling SQL to use OptiConnect 50
- End Subsystem (ENDSBS) command 23
- ending 23
  - OptiConnect system 23
- ENDSBS command 23
- entries 20
  - autostart job 20
  - job queue 20
  - routing 20
- error code 67
- establishing OptiConnect routing 50
- establishing system connections 66
- even bus 12
- example 12
- expansion tower 17
- experiencing problems with
  - OptiConnect? 66
- extended dynamic SQL 50
- Extended Function Plan routing 39
- external bus 12

**F**

- F14), Work with OptiConnect Jobs
  - (WRKOPCACT, 27
- failing link 17
- failure of an IPL 66
- feature codes 12
- fiber optic cable 3
- fields in the mode table 52
- figures 20
  - Display Autostart Job Entries 20
  - Display Job Description 22
  - Display Job Queue Entries 21
  - Display Routing Entry Detail 21
  - Displaying Resource Serial Numbers
    - and Locations 35
  - Work with Active Jobs display 24
  - Work with Coupled Resources
    - display 35
  - Work with OptiConnect Activity
    - display 25
- finding out how OptiConnect is
  - running 24
- frame ID 35

**G**

- getting information on OptiConnect
  - activity 24
- GRTOBJAUT 39

**H**

- hardware 1
- hardware failure 66
- hardware requirements 11
- hardware requirements for OptiConnect
  - RPQ 12
- hardware resources 35
- high availability 1
- High Speed Link OptiConnect 3
- horizontal growth 1
- how to 20
  - display autostart job entries 20
  - display hardware resources 36
  - display job queue entries 20
  - display QSOC subsystem
    - description 20
  - display routing entries 20
  - end the OptiConnect system 23
  - get information on OptiConnect
    - activity 24
  - optimize OptiConnect
    - performance 49
  - power down systems when
    - OptiConnect is installed 66
  - reestablish system connections 66
  - resolve not detected resources 35
  - see active jobs in QSOC
    - subsystem 24
  - set up routing for OptiConnect 50
  - setting up routing for
    - OptiConnect 37
  - start your OptiConnect system 23
  - use OptiConnect 44
  - use Work with OptiConnect Activity
    - command 25

- HSL Loop technology 3
- HSL OptiConnect 1, 3, 31
- hub system 3
- Hub system 17

**I**

- I/O Expansion Tower 3
- information, related 75
- Informational RPQ 843871 11, 12
- initial library list 44
- initial program load 66
- initiating OptiConnect 23
- inoperative system-to-system
  - connections 66
- installation
  - hardware 15
  - verifying software 15
- installation verification 11
- installing 15
  - hardware, verification 15
- installing OptiConnect 11
  - instructions 11
- interactive workload 18
- interoperability 3
- interrupted IPLs 66
- introduction to OptiConnect 1
- IPL 35, 66
- IPL failure 66
- IPL precautions 66
- iSeries 400 1

**J**

- job class
  - QYYCAGNT 49
- job class, adjusting for performance 49
- job description
  - QYYCDTSU 37, 44, 46
  - QYYCMGR 44, 47
- job descriptions 19, 22
  - QYYCDTSU 19, 22
  - QYYCDTSU job 46
  - QYYCDTSU job description 45
  - QYYCMGR 19, 22
  - QYYCMGR job 47
  - QYYCSRA 19
- job entries autostart 20
- job priority, adjusting for
  - performance 49
- job queue, QSOC 19
- job queue entries 20
- jobs
  - active 24
  - SOCAnnnnnn 19
  - SOCMGR 19
- Jobs (WRKOPCACT, F14), Work with
  - OptiConnect 27
- journalling OptiConnect transactions 57

**L**

- learning about OptiConnect
  - components 19
- library, QSOC 19
- library list
  - changing QYYCDTSU 45

- link 17
- link redundancy 17
- LINKTYPE 39
- listing active OptiConnect jobs 24
- local bus information 31
- LOCLOCNAME 39
- logical partitioning 1
- logical path 17
- Loop technology, HSL 3

## M

- major/minor codes 67
- messages 15
  - displaying OptiConnect 67
  - successful initiation of OptiConnect connection manager 15
- methods for setting up OptiConnect routing
  - \*OPC type controller and device routing 37
  - standard OptiConnect routing 37
- Migration 3
- MODE 39
- mode of QYCTSOC 52
- mode parameter 37, 52
- mode table 52
- mode table reload
  - connection manager 56

## N

- Network Printer Passthrough 8
- non-OptiConnect tower 12, 66
- not detected resources 35
- number of bytes read 25
- number of bytes written 25
- number of transactions 25

## O

- ObjectConnect/400 8, 19
- odd bus 12
- ONLINE (Online at IPL) 39
- operating 44
  - OptiConnect 44
- Optical Link card 17
- optical link status 31
- OptiConnect 1, 67
  - benefits 2
  - Bus Receiver card 3
  - Bus Receiver Card 17
  - cluster 3, 23
  - cluster diagnostics 69
  - collecting activity data 25
  - customization 44
  - hardware 1
  - hardware requirements 12
  - hub system 3
  - installation 11
  - installing 11
  - introduction 1
  - journaling 57
  - library 23
  - link 17
  - messages 67
  - path 17

- OptiConnect 1, 67 (*continued*)
  - performance 23
  - problem determination 66
  - QMSAMPLE 52
  - QMTABLE 52
  - QSOC 23
  - QYYCMGR 22
  - RELOAD 56
  - routing 37
  - RPQ's 12
  - satellite system 3
  - software 1, 11
  - subsystem 23
  - verifying 11
- OptiConnect, HSL 1, 3, 31
- OptiConnect, SPD 1, 3
- OptiConnect, Virtual 1
- OptiConnect adapter information 35
- OptiConnect Bus Receiver Card 17
- OptiConnect Capabilities
  - Business Partner Applications 8
  - DB2 Multisystem for OS/400 8
  - Distributed Data Management (DDM) 8
  - Distributed Relational Database Architecture (DRDA) 8
  - ObjectConnect/400 8
  - Standard APPC Conversations 8
  - System Network Architecture Distribution Services (SNADS) 8
- OptiConnect cluster 17
- OptiConnect connection manager 65
- OptiConnect for OS/400 1
  - activity 24
  - autostart job 19
  - autostart job entries 20
  - components, overview 19
  - connection manager 19
  - ending the system 23
  - environment 18
  - getting information on activity 24
  - hardware requirements 12
  - how does it work? 3
  - job queue entries 20
  - OptiConnect/400 Capabilities 8
  - optimizing performance 49
  - QSOC subsystem 20
  - QYYCDTSU job description 45, 46
  - QYYCMGR job description 22, 47
  - routing entries 20
  - setting up routing with Relational Database Directory 50
  - user profile 19
  - verifying hardware installation 15
  - verifying software installation 15
  - what is it? 1
- OptiConnect Jobs (WRKOPCACT, F14), Work with 27
- OptiConnect messages 67
- OptiConnect over TCP/IP 64
- OptiConnect performance factors 44
- OptiConnect subsystem, QSOC 23
- optimizing OptiConnect performance 49
- OptiMover for OS/400 1
- option 23 for OptiConnect 11
- OS/400 1
- over TCP/IP, OptiConnect 64

- overview 1
  - OptiConnect 1
  - OptiConnect components 19
  - OptiConnect environment 18

## P

- partitioning, logical 1
- path 17
- path redundancy 17
- percent utilization of bus 25
- performance 44
  - number of agents allowed in pool 49
  - prestarted agent jobs 23
  - prestarted jobs 49
  - shutdown 49
  - start up time 23
- performance, optimizing 49
- planning your OptiConnect installation 11
- power down precautions 66
- Power Down System (PWRDWN SYS)
  - command 66
- powering down when OptiConnect installed 66
- prestarted jobs 23
- problem analysis
  - OptiConnect connection manager 65
  - OptiConnect DDM access failing 65
  - QSOC subsystem 65
  - SOCMGR job 65
  - verifying communications between source and target 65
  - verifying system-to-system connections 65
- problems with OptiConnect 65
- Product Activity Log 69
- PRPQ (OptiMover) 1
- PWRDWN SYS 66

## Q

- QCPFMSG message file 67
- QMTABLE 52
  - keyed fields 52
  - LCLLOC 52
  - MODE 52
  - RMTLOC 52
- QSOC library 11, 19
  - autostart job 19
  - commands 19
  - job description 19
  - job queue 19
  - jobs 19
  - library 19
  - routing entries 19
  - subsystem 19
  - user profile 19
- QSOC subsystem 20, 23, 24
- QSYS library
  - QCPFMSG message file 67
- QUSER 44
- QUSER user profile 15
- QUSER usrprf
  - changing QYYCDTSU 45
- QYCTSOC 37

QYCTSOC, adding to DDM file for device 37  
 QYCTSOC, adding to DDM file for device description 50  
 QYYCAGNT class 49  
 QYYCDTSU 21, 45, 46  
 QYYCDTSU job description 19, 37, 44  
 QYYCMGR 47  
 QYYCMGR job description 19, 22, 44  
 QYYCROUT program 57  
 QYYCSRA job description 19

## R

RCLDDMCNV command 24  
 RCLRSC command 24  
 Reclaim DDM Conversation (RCLDDMCNV) command 24  
 Reclaim Resource (RCLRSC) command 24  
 reestablishing system-to-system connections 66  
 related information 75  
 relational database directory entries 50  
 remote job submission 57  
 remote journal function 51  
 remote location parameter 37, 50  
 remote output queue 57  
 Remote unit of work (\*RUW) 50  
 request data parameters, adjusting for performance 49  
 resources, not detected 35  
 RMTLOCNAME 39  
 ROLE 39  
 routing entries 19, 20  
 routing SNADS over OptiConnect 44  
 routing with Relational Database Directory 44  
 running OptiConnect 44  
 RVKOBJAUT 39

## S

satellite system 3  
 Satellite system 17  
 Save Licensed Program (SAVLICPGM) command 11  
 SAVLICPGM command 11  
 SBMDBJOB command 57  
 SBMJOB command 57  
 serial numbers 35  
 setting up Extended Function Plan Routing 39  
 setting up OptiConnect routing 37  
 setting up OptiConnect routing with Relational Database Directory 50  
 setting up standard OptiConnect routing 37  
 shutting down OptiConnect 23  
 shutting off power to systems 66  
 single hub configuration 12  
 SOCAAnnnnnn job 19, 24  
 SOCAAnnnnnn job description 22  
 SOCMGR job 19, 24, 65  
 SOCVRFY program 15  
 software 1  
 software installation, verification 15

software requirements 11  
 SPD OptiConnect 1, 3  
 specifying remote location parameter 37, 50  
 SQL 8, 50  
 SQL over OptiConnect 39  
 SRCs 69  
 Standard APPC Conversations  
   \*OPC type controller and device routing 8  
   Multiple mode support 8  
   Two-phase commit 8  
 Start Subsystem (STRSBS) command 15, 23  
 starting the OptiConnect subsystem 23  
 static SQL 50  
 status  
   not detected 35  
   operational 35  
 stopping OptiConnect system 23  
 stopping prestarted agent jobs 23  
 storage pool, adjusting for performance 49  
 STRRMTWTR command 57  
 STRSBS command 23  
 Structured Query Language 50  
 Structured Query Language (SQL) 39  
 subsystem, QSOC 20  
 System Cabling Informational RPQ 841958 11, 12  
 system connections  
   establishing 66  
 System I/O Expansion Tower 17  
 system power downs 66  
 system-to-system connections 65  
 system-to-system connections, inoperative 66  
 system-to-system connections, reestablishing 66

## T

tables 12  
   Additional Sources of Information 75  
   Hardware Required for OptiConnect System 12  
 target job 57  
 TCP/IP, OptiConnect over 64  
 technology, HSL Loop 3  
 terminating OptiConnect system 23  
 total KBytes/second 25  
 tower  
   non-OptiConnect 12, 66  
 transactions 25  
 tuning OptiConnect performance 49  
   agent jobs allowed in storage pool 49  
   job class 49  
   minimum number of agents in system 49  
   request data parameters 49  
   SOCMGR agent job control parameters 49  
   storage pool 49  
 turning off power when OptiConnect installed 66  
 two-phase commit 50

## U

uninterruptible power supply failure 66  
 use of modes 52  
 user profile, QUSER 45  
 user profile default, QUSER 15  
 user profile for OptiConnect 19  
 utility or uninterruptible power supply failure 66

## V

Vary Configuration (VRYCFG) 39  
 verifying 15  
   hardware connections are operational 15  
   hardware installation 15  
   software installation 15  
 verifying communications established between source and target 65  
 verifying software installation 11  
 VFYOPCCNN 15  
 Virtual OptiConnect 1  
 VRYCFG command 39

## W

why your system-to-system connections are inoperative 66  
 with OptiConnect Jobs (WRKOPCACT, F14), Work 27  
 Work with Active Job display 24  
 Work with Active Jobs (WRKACTJOB) command 24  
 Work with Hardware Resources (WRKHDWRSC) command 35  
 Work with Message File (WRKMSGF) command 67  
 Work with OptiConnect Activity (WRKOPCACT) command 19, 25  
 Work with OptiConnect Activity display 25  
 Work with OptiConnect Jobs (WRKOPCACT, F14) 27  
 WRKACTJOB 24  
 WRKHDWRSC 35  
 WRKHDWRSC command 15  
 WRKLCIPGM command 11  
 WRKMSGF 67  
 WRKOPCACT 25  
 WRKOPCACT command 19

---

## Readers' Comments — We'd Like to Hear from You

iSeries  
OptiConnect for OS/400  
Version 5

Publication No. SC41-5414-02

Overall, how satisfied are you with the information in this book?

	Very Satisfied	Satisfied	Neutral	Dissatisfied	Very Dissatisfied
Overall satisfaction	<input type="checkbox"/>	<input type="checkbox"/>	<input type="checkbox"/>	<input type="checkbox"/>	<input type="checkbox"/>

How satisfied are you that the information in this book is:

	Very Satisfied	Satisfied	Neutral	Dissatisfied	Very Dissatisfied
Accurate	<input type="checkbox"/>	<input type="checkbox"/>	<input type="checkbox"/>	<input type="checkbox"/>	<input type="checkbox"/>
Complete	<input type="checkbox"/>	<input type="checkbox"/>	<input type="checkbox"/>	<input type="checkbox"/>	<input type="checkbox"/>
Easy to find	<input type="checkbox"/>	<input type="checkbox"/>	<input type="checkbox"/>	<input type="checkbox"/>	<input type="checkbox"/>
Easy to understand	<input type="checkbox"/>	<input type="checkbox"/>	<input type="checkbox"/>	<input type="checkbox"/>	<input type="checkbox"/>
Well organized	<input type="checkbox"/>	<input type="checkbox"/>	<input type="checkbox"/>	<input type="checkbox"/>	<input type="checkbox"/>
Applicable to your tasks	<input type="checkbox"/>	<input type="checkbox"/>	<input type="checkbox"/>	<input type="checkbox"/>	<input type="checkbox"/>

Please tell us how we can improve this book:

Thank you for your responses. May we contact you?  Yes  No

When you send comments to IBM, you grant IBM a nonexclusive right to use or distribute your comments in any way it believes appropriate without incurring any obligation to you.

---

Name

---

Address

---

Company or Organization

---

Phone No.



Fold and Tape

Please do not staple

Fold and Tape



NO POSTAGE  
NECESSARY  
IF MAILED IN THE  
UNITED STATES

# BUSINESS REPLY MAIL

FIRST-CLASS MAIL PERMIT NO. 40 ARMONK, NEW YORK

POSTAGE WILL BE PAID BY ADDRESSEE

IBM CORPORATION  
ATTN DEPT 542 IDCLERK  
3605 HWY 52 N  
ROCHESTER MN 55901-7829

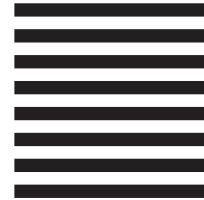

Fold and Tape

Please do not staple

Fold and Tape





Printed in the United States of America  
on recycled paper containing 10%  
recovered post-consumer fiber.

SC41-5414-02

